

DPA500

DP A 500 F -360

① ② ③ ④ ⑤



- ① Series name
- ② Single output
- ③ Output wattage
- ④ Universal input
- ⑤ Output voltage

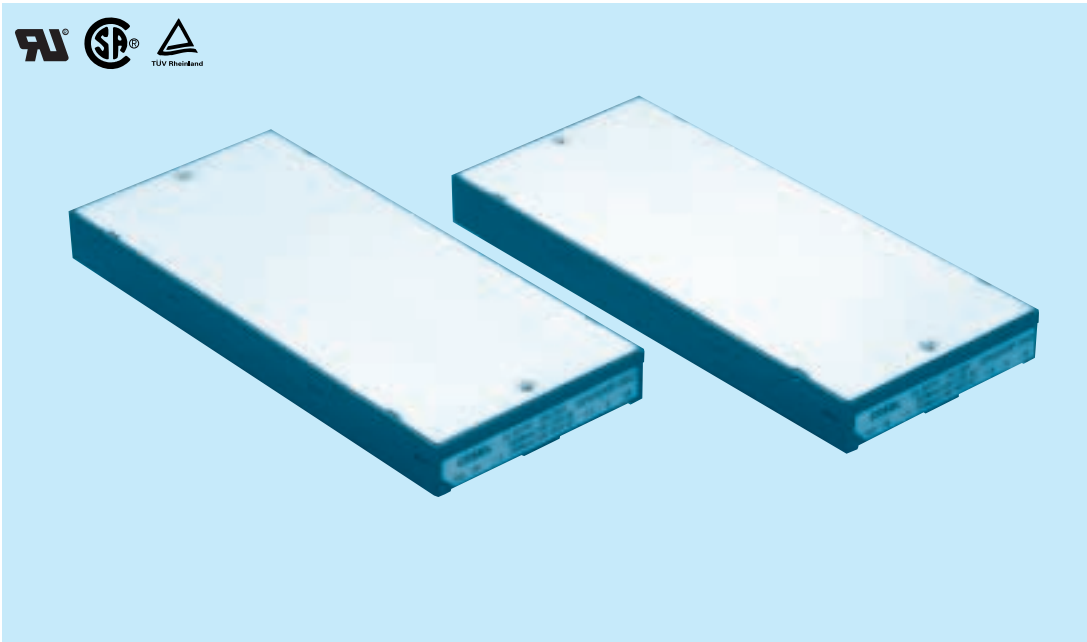

MODEL	DPA500F-360	
AC INPUT[V]	AC85 - 264	AC170 - 264
MAX OUTPUT WATTAGE[W]	500	750
DC OUTPUT VOLTAGE[V]	DC300 - 360	

SPECIFICATIONS

	MODEL	DPA500F-360
INPUT	VOLTAGE[V]	AC100/120 AC200/240
	VOLTAGE RANGE[V]	AC85 - 170 AC170 - 264
	POWER FACTOR CORRECTION RANGE[V]	AC85 - 255
	CURRENT[A]	5.6typ (ACIN 100V) 4.0typ (ACIN 200V)
	FREQUENCY[Hz]	47 - 63
	APPARENT POWER[VA]	560typ (ACIN 100V) 800typ (ACIN 200V)
	INRUSH CURRENT[A]	15typ (ACIN 100V) 30typ (ACIN 200V)
	EFFICIENCY[%]	90typ (ACIN 100V) 95typ (ACIN 200V)
	POWER FACTOR	0.98typ (Complies with IEC61000-3-2)
OUTPUT	LEAKAGE CURRENT[mA]	Less than 0.3
	WATTAGE[W]	500 750
PROTECTION CIRCUIT AND OTHERS	VOLTAGE[V]	DC300 - 360 (Automatically changes according to input voltage)
	OVERVOLTAGE PROTECTION[V]	DC390 - 440
	IOG	Inverter operation monitoring, Open-collector output. Maximum sink current 5mA, Maximum allowance voltage 35V
	PR	Power-ready signal, Open-collector output. Maximum sink current 5mA, Maximum allowance voltage 35V
	AUX	Auxiliary power supply for external signal, Output voltage:10 - 20V maximum, Output current:10mA
ISOLATION	OTHERS	Inrush current protection, Parallel operation possible (Current balancing function), Thermal protection
	INPUT-OUTPUT	Non isolated
	INPUT-FG	AC3.000V 1minute, Cutoff current = 10mA, DC500V 50MΩ min (At Room Temperature)
ENVIRONMENT	OUTPUT-FG	AC3.000V 1minute, Cutoff current = 10mA, DC500V 50MΩ min (At Room Temperature)
	OPERATING TEMP., HUMID. AND ALTITUDE	-20 to +85°C (Aluminum base plate), 20 - 95%RH (Non condensing) (Refer to DERATING CURVE), 3,000m (10,000feet) max
	STORAGE TEMP., HUMID. AND ALTITUDE	-40 to +85°C, 20 - 95%RH (Non condensing), 9,000m (30,000feet) max
	VIBRATION	10 - 55Hz, 49.0m/s ² (5G), 3minutes period, 60minutes each along X, Y and Z axis
SAFETY	IMPACT	196.1m/s ² (20G), 11ms, once each X, Y and Z axis
	AGENCY APPROVALS	UL1950, CSA C22.2 No.234, EN60950, VDE0160 Complies with DEN-AN and IEC60950
OTHERS	CASE SIZE/WEIGHT	58 × 12.7 × 130mm (W × H × D) / 150g max
	COOLING METHOD	Conduction cooling (e.g. heat radiation from the aluminum base plate to the attached heat sink)

External view

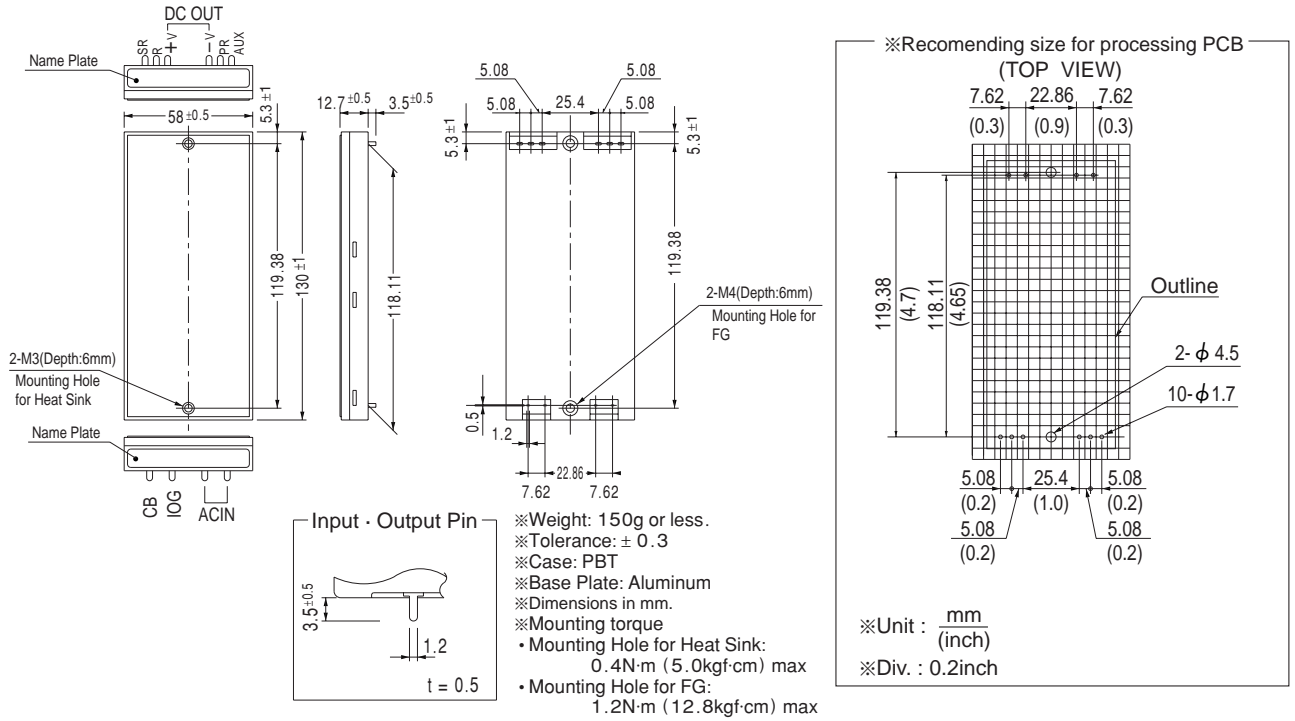

Performance data

■ STATIC CHARACTERISTICS

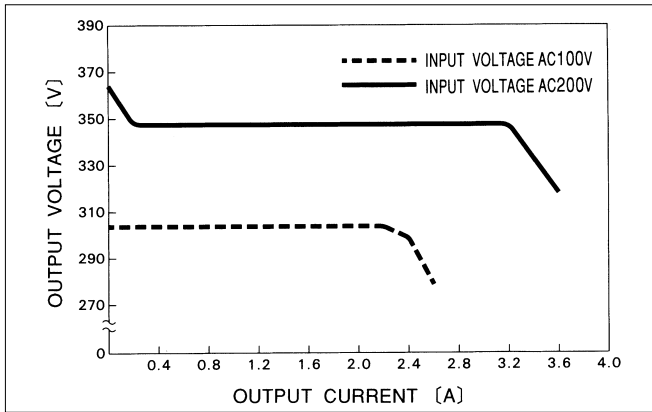

■ OUTPUT VOLTAGE FOR INPUT

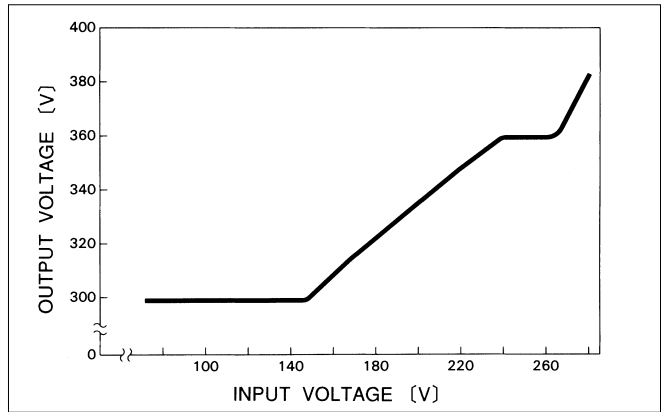

■ HARMONIC CURRENT (AC100V)

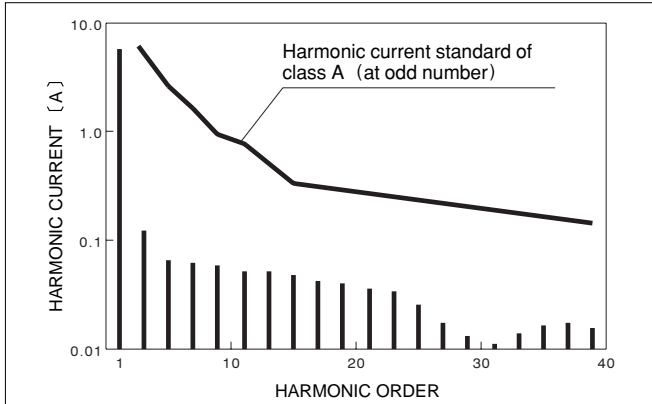

■ HARMONIC CURRENT (AC200V)

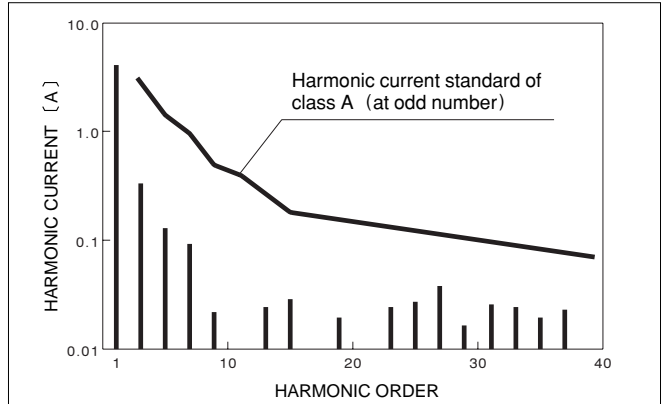

1	Pin Connection	G-8
2	Function	G-8
2.1	Overvoltage protection	G-8
2.2	Thermal protection	G-8
2.3	Isolation	G-8
2.4	Sequence	G-8
3	Wiring Input/Output Pin	G-9
3.1	Wiring to input pin	G-9
3.2	Wiring to output pin	G-9
4	Series and Parallel Operation	G-9
5	Implementation · Mounting Method	G-10
5.1	Mounting method	G-10
5.2	Derating	G-10
6	Cleaning	G-10
7	Input/Output Pin	G-11
8	External Fuse	G-11
9	Inrush Current Limiting	G-11
10	Inverter Operation Monitor	G-11
11	Power Ready	G-12
12	Auxiliary Power Supply Circuit for External Signal	G-12
13	Thermal Design	G-12
14	Mounting Screw	G-13
15	Noise Filter Design	G-13
16	Selection of Output Filtering Capacitor	G-15
17	Connection to Back-End Units	G-16

1 Pin Connection

Table 1.1 Pin connection and function

No.	Pin connection	Function
①	CB	Current balance
②	IOG	Inverter operation monitor
③	AC	AC Input
④	AC	
⑤	SR	Inrush current protection
⑥	R	External resistor for inrush current protection
⑦	+V DC OUT	+DC(+V) output
⑧	-V DC OUT	-DC(-V) output
⑨	PR	Power ready signal
⑩	AUX	Auxiliary power supply for external signal
—	FG	Frame ground

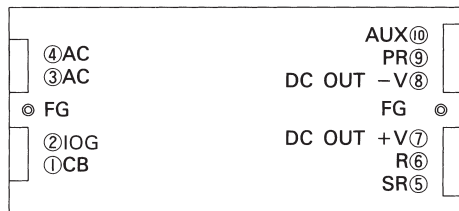

Fig. 1.1 Pin connection(bottom view)

2 Function

2.1 Overvoltage protection

■The overvoltage protection circuit is built-in and comes into effect at more than 390V of output voltage. The AC input should be shut down if overvoltage protection is in operation. The minimum interval of AC recycling for recovery is a few minutes which output voltage drops below 20V(approximately 90 seconds for an electrolytic capacitor with 600μF).

When this function operates, the power factor corrector function does not operate, and output voltage becomes the full-wave rectified AC input voltage.

DPA

Remarks:

Please note that the unit's internal components may be damaged if excessive voltage(over rated voltage)is applied to output terminal of power supply. This could happen when the customer tests the overvoltage performance of the unit.

2.2 Thermal protection

■Thermal protection circuit is built-in and it operates at 100±15°C. If this function comes into effect, shut down the output, eliminate all possible causes of overheating, and drop the temperature to normal level. To prevent the unit from overheating, avoid using the unit in a dusty, poorly ventilated environment.

When this function operates, the power factor corrector function does not operate, and output voltage becomes the full-wave rectified AC input voltage.

2.3 Isolation

■For a receiving inspection, such as Hi-Pot test, gradually increase (decrease) the voltage for the start(shut down). Avoid using Hi-Pot tester with the timer because it may generate voltage a few times higher than the applied voltage, at ON/OFF of a timer.

2.4 Sequence

■The sequence of IOG, PR and AUX pins is illustrated below(rated input and output power).

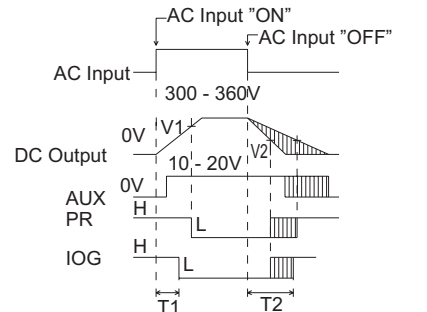

▨ shows the areas which depend on Load.

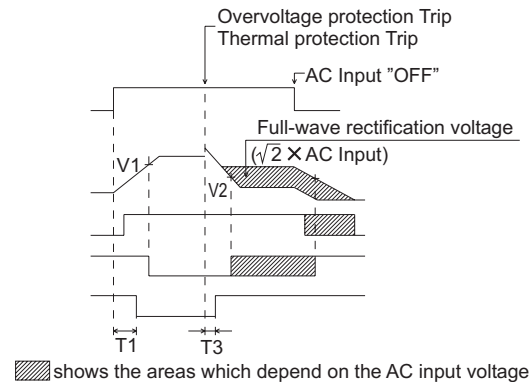

▨ shows the areas which depend on the AC input voltage

- V1=270V typ T1=200ms typ
- V2=190V typ T2=250ms typ
- T3=10ms max

Fig. 2.1 Sequence

■Breaking the load

When the overvoltage protection and/or thermal protection is operated, terminate either the DAS or the connected back end (load) unit using PR or IOG signal(Refer to Fig.11.1 for a sample circuit).

3 Wiring Input/Output Pin

3.1 Wiring to input pin

■External noise filter to input pin

The unit does not have a built-in noise filter. Connect an external noise filter to reduce the conducted noise to the power supply line. Refer to Fig.3.1 for recommended circuit for the noise filter.

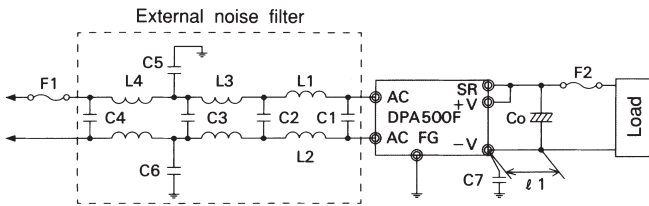

- L1=L2=190μH
- L3=L4=3mH (Leakage inductance 30μH)
- C1=C2=0.47μF
- C3=C4=0.47μF
- C5=C6=2200pF
- C7=1000pF
- Co=400V 120 - 1,000μF (Avoid to use above 1,000μF for Co)
- F1=AC250V10A
- F2=DC400V3A(In case of DAS100)
- l1=50mm^{max}

Fig.3.1 Example of the recommended circuit for noise filter

The example of the recommended circuit above satisfies the standards for FCC-B, VDE-B and VCCI-2. Note that the effect of noise level reduction varies depending on the design of the circuit. Contact the factory for further assistance.

3.2 Wiring to output pin

■External filtering capacitor to output pin

The unit does not have a built-in output filtering capacitor. Connect an electrolytic capacitor Co(120 - 1,000μF) to the output pins as shown in Fig.3.1. Use a high ripple long life capacitor. Avoid connecting Co above 1,000μF to output, it may severely damage the unit. Contact the factory for further assistance.

- Application of an external voltage exceeding the rated value to the output pins may damage the circuits. Take special caution when mounting the unit and wiring.
- Never make a short-circuit between the output pins or make connections between the pins that are not specified in the manual. It may severely damage the unit.

4 Series and Parallel Operation

■The unit cannot be operated in series.

■As variance of output current drew from each power supply is maximum 10%, the total output current must not exceed the value determined by the following equation.

(Output current in parallel operation)

$$= (\text{the rated current per unit}) \times (\text{number of units}) \times 0.9$$

When the number of units in parallel operation increases, input current increases at the same time.

Adequate wiring design for input circuitry is required, such as circuit pattern, wiring and current capacity for equipment.

In parallel operation, the maximum operative number of units is 5.

■The load regulation will deteriorate as the difference in the output voltage increases due to the line drop of the output wiring. Make sure to design the wiring to minimize the line drop.

■In parallel operation, please connect diode to the +side of the output circuit. If diode is connected to the -side, it will damage the unit or/and, the balancing function will not work.

■When the unit is not operated in parallel, open the CB pin.

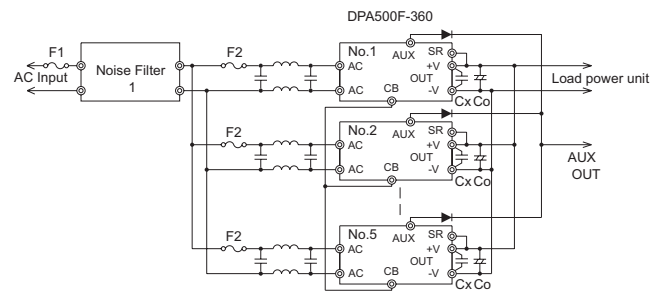

Fig.4.1 Connection for parallel operation

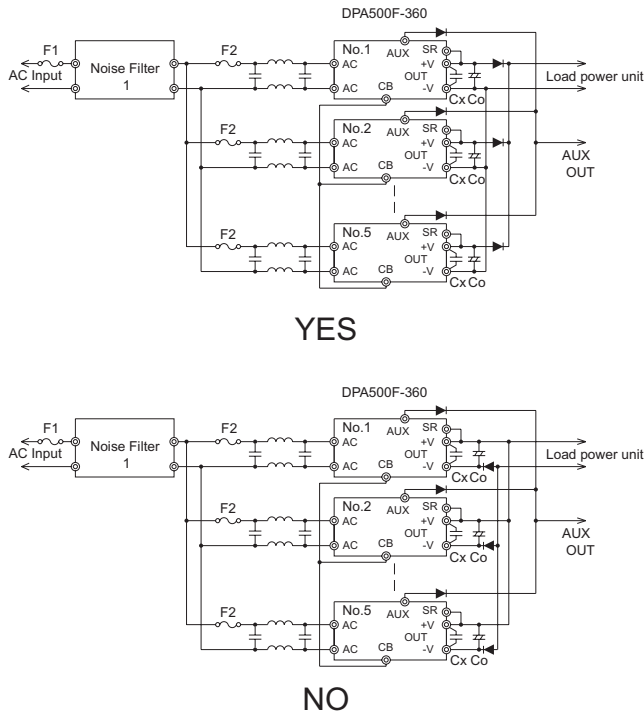

Fig.4.2 When connected diode at output circuit for parallel operation

5 Implementation Mounting Method

5.1 Mounting method

- The unit can be mounted in any direction. When two or more power supplies are used side by side, position them with proper intervals to allow enough air ventilation. Aluminum base plate temperature around each power supply should not exceed the temperature range shown in derating curve.
- Avoid placing the AC input line pattern lay out underneath the unit because it will increase the line conducted noise. Make sure to leave an ample distance between the line pattern lay out and the unit. Also, avoid placing the DC output line pattern underneath the unit because it may increase the output noise conducted noise. Lay out the pattern away from the unit.

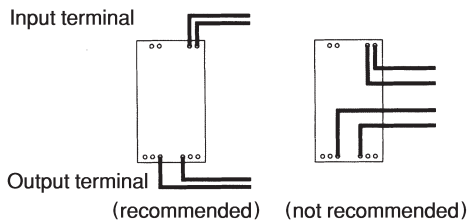

Fig.5.1 Pattern lay out

- High-frequency noise radiates directly from the unit to the atmosphere. Therefore, design the shield pattern on the printed circuit board and connect its one end to FG. The shield pattern prevents noise radiation.

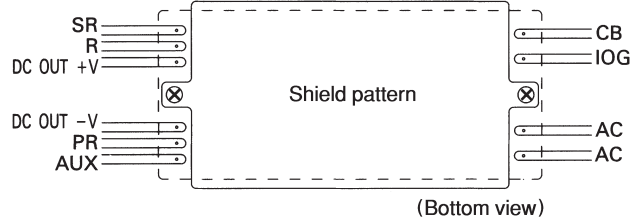

Fig.5.2 Shield pattern lay out

- When a long wire is used between the front-end unit and a back-end unit (DAS50F, DAS100F etc.), the RF noise voltage may increase due to the resonance of the wiring and the decoupling capacitor. Install a common mode choke (0.5mH - 2mH for each power supply). In this case, the input ripple of the back-end unit will increase due to the increase of the line impedance to the back-end unit. Make sure to connect the capacitor to the input pins of the back-end unit as shown in the recommended samples.

5.2 Derating

- Use with the conduction cooling (e.g. heat radiation by conduction from the aluminum base plate to the attached heat sink). Fig.5.3 shows the derating curve in terms of the aluminum base plate temperature.

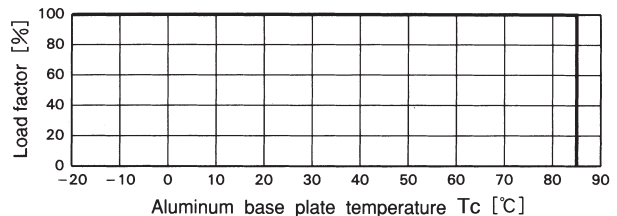

Fig.5.3 Derating curve

6 Cleaning

- Clean the product with a brush. Prevent liquid from getting into the product. Do not soak the product into liquid.
- Do not stick solvent to a name plate or a resin case. (If solvent sticks to a name plate or a resin case, it will cause to change the color of the case or to fade letters on name plate away.)
- After cleaning, dry them enough.

7 Input/Output Pin

- When too much stress is applied on the input/output pins of the unit, the internal connection may be weakened. As below Fig.7.1, avoid applying stress of more than 29.4N(3kgf) on the pins horizontally and/or vertically.
- The input/output pins are soldered on PCB internally, therefore, do not bend or pull them with abnormal forces.

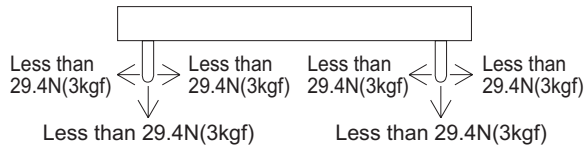

Fig.7.1 Stress onto the pin

- When additional stress is expected to be put on the input/output pins because of vibration or impacts, fix the unit on PCB(using the silicone rubber or fixing fittings) to reduce the stress onto the input/output pins.

8 External Fuse

- Fuse is not built-in at input side. In order to secure the safety of the unit, use the 250V10A slow-blow type fuse at input.
- When more than one units are used, for example for a parallel operation, install a fuse for each unit.

9 Inrush Current Limiting

Use of the following pins(SR or R) will reduce the inrush current when AC input voltage is applied. They prevent blowing the input fuse, welding of the switches and relays, and cutting off the no-fuse-breaker.

Note that either of the following pins must be connected to the +V pin to start the unit.

■SR pin

By connecting the SR pin and the +V pin, the inrush current can be reduced when the AC input voltage is applied. The interval between the AC input must be more than 7 seconds each time the AC input is applied.

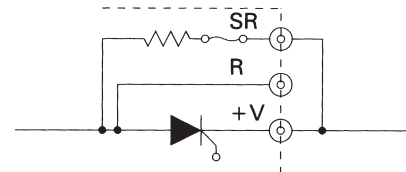

$$\text{Inrush current} = \frac{15\text{A}_{\text{typ}}(\text{AC } 100\text{V})}{30\text{A}_{\text{typ}}(\text{AC } 200\text{V})}$$

Fig.9.1 Inrush current limiting circuit using the SR pin

■R pin

In order to set the inrush current at a desired level, connect an inrush current limiting resistor R1 between the R pin and the +V pin, and open the SR pin. Make sure to connect an external resistor with 10Ω or more to prevent a malfunction caused by the input surge current. Also, use the resistor which has a capacity to withstand a large enough surge and which has a built-in thermal fuse. Ask your parts manufacturer regarding the surge current withstanding capacity of the external resistor.

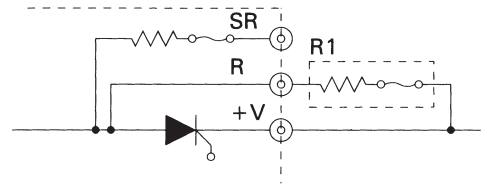

$$\text{Inrush current} = \frac{\sqrt{2} \times \text{AC input voltage}}{R1}$$

Fig.9.2 Inrush current limiting circuit using an external resistance R1

10 Inverter Operation Monitor

- By using an IOG pin, normal/abnormal operation of the unit can be monitored. The IOG pin is an open collector(maximum applicable voltage: 35V, maximum sink current 5mA). When the inverter operates normally, the level is set to "Low"(0 - 1.2V). When the power factor connector action terminates due to the AC input shutdown or protection circuit action, the level is set to "High"(open collector).

- Refer to Fig.2.1 for the sequence of the IOG signal.

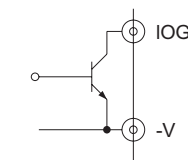

"L" = 0 - 1.2V
"H" = Open collector

Fig.10.1 IOG pin

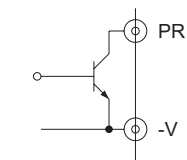

Maximum sink current = 5mA
Maximum applicable voltage = 35V

Fig.10.2 PR pin

11 Power Ready

- By using a PR pin, the output voltage of the unit can be monitored. The PR pin is an open collector(maximum applicable voltage: 35V, maximum sink current 5mA). When the output voltage is beyond the rated range, the level is set to "Low"(0 - 1.2 V). Refer to Fig. 2.1 for the sequence of the PR signal.
- By combining the PR signal and the IOG signal, the start-up timing of the DC-DC Converter(DAS Series), the back-end unit, can be controlled normally. The DC-DC Converter(DAS Series) is to be started when both the PR signal and the IOG signal come to the "Low" level. When either of the two is at the level of "High", the back-end DC-DC Converter(DAS Series) will terminate.

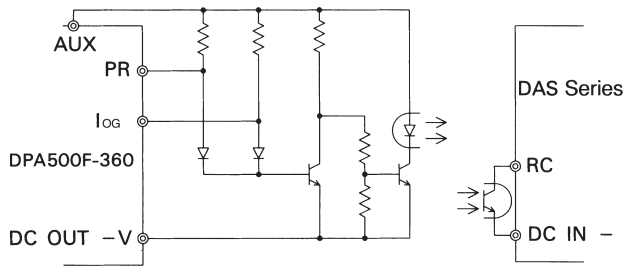

Fig.11.1 Example of connection to the DAS Series

12 Auxiliary Power Supply Circuit for External Signal

- The AUX pin can be used as the power source with the open collector output(Output voltage DC 10 - 20V, maximum output current 10mA) for IOG and PR.
- When used with AUX pin of additional units of this model for parallel connection, make sure to install a diode and that the maximum output current must be below 10mA. Refer to the example shown in Fig.4.1 for connection.
- Never let a short circuit occur between the AUX pin and other pins. It may damage the unit.

13 Thermal Design

- The unit relies on the aluminum base plate to transfer the inner losses by conduction cooling to free air. The aluminum base plate temperature must be kept below 85°C and therefore the unit requires the thermal design just as the power semiconductor does.

(1)Fig.13.1 shows the recommended value to use for the thermal resistance of the heat sink in terms of the temperature. It is calculated based on the required output wattage. These values show the thermal resistance of the heat sink with the aluminum base temperature at 85°C. In order to obtain maximum reliability, keep the aluminum base plate temperature low.

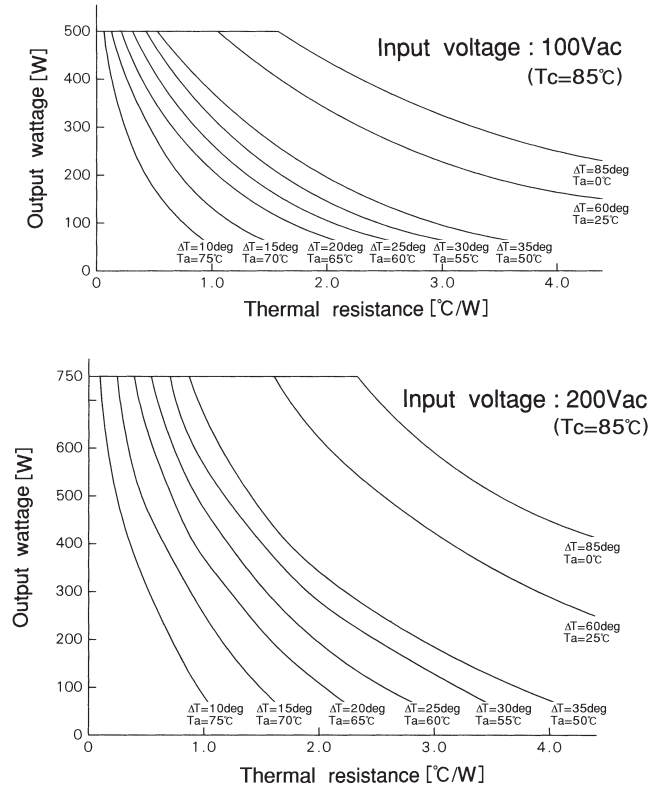

Fig.13.1 Output wattage and the thermal resistance of the heat sink

●Design examples

①Finding out the thermal resistance of the heat sink.

Assumption: The aluminum base plate temperature(Tc) is 85°C.

The ambient temperature (Ta) is 60°C .

$$\Delta T = T_c - T_a = 85 - 60 = 25(\text{deg})$$

Maximum output wattage to deliver is 500W.

Reading the value at point A in Fig.13.2, it is 0.9(°C/W).

②Finding out the ambient temperature for a given thermal resistance.

Assumption: The aluminum base plate temperature(Tc) is 85°C.

The thermal resistance of the heat sink is 2.0(°C/W).

The output wattage to deliver is 300W.

Reading the value at point B in Fig.13.2, it is ΔT=31deg.

$$T_a = T_c - \Delta T = 85 - 31 = 54^\circ\text{C}$$

③ Finding out the thermal resistance of the heat sink.

Assumption: The aluminum base plate temperature(T_c) is 75°C.

The ambient temperature(T_a) is 65°C.

$$\Delta T = T_c - T_a = 75 - 65 = 10 \text{ deg}$$

Maximum output wattage to deliver is 500W

Reading the value at point C in Fig.13.2, it is 0.6°C/W.

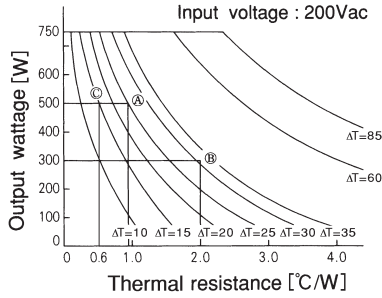

Fig.13.2 Design examples

(2) The thermal resistance of the heat sink varies depending on the operating condition. It is, for example, affected by the condition of air convection around the heat sink when used under convection cooling, and by the air flow of the fan when used under the forced air cooling. By using the selected heat sink, make sure that the base plate temperature is below the designed level.

(3) Apply the silicone grease at the junction to reduce the thermal resistance.

14 Mounting Screw

■ Mounting to Heat Sink

Mount the unit to the heat sink using M3 screws. The maximum value of the tightening torque is 0.4N · m(5kg f · cm). The insertion depth of the screw should be less than 6mm.

■ Mounting to Mounting board

Mount the unit to the mounting board using M4 screws. The maximum value of the tightening torque is 1.2N · m(12.8kg f · cm). The insertion depth of the screw should be less than 6mm.

15 Noise Filter Design

■ Fig.3.1 in Section 3.1 illustrated the external connection filters. The number of parts can be reduced by making the noise standard specific. Recommended samples of noise filter circuits which would meet the various standards are shown below.

(1) VCCI -A, VCCI-B, CISPR22-B recommended circuit

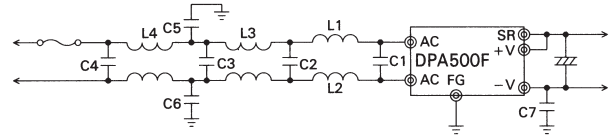

(2) FCC-B recommended circuit

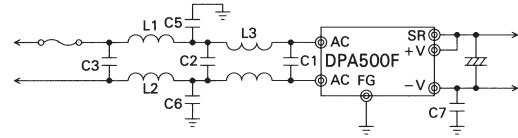

(3) FCC-A recommended circuit

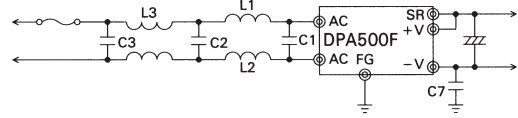

★1 The circuits and constants in the examples on the left assume the ideal design and installation. The noise may vary greatly, depending on the implementation, being affected by the stray capacity, wiring inductance and leakage flux. Check if the noise filter is appropriate on the final product. Consult with the factory for further assistance.

① Recommended circuit constants for 100VAC, 500W

Table 15.1.1 Table of constants(100VAC, 500W)

No.	Standard		VCCI · B CISPR22-B	VCC · A	FCC · B	FCC · A
	Symbol	Product name				
1	C1	Film capacitor	250V 0.47μF	250V 0.47μF	250V 0.47μF	250V 0.47μF
2	C2	Film capacitor	250V 0.47μF	250V 0.47μF	250V 0.47μF	250V 0.47μF
3	C3	Film capacitor	250V 0.47μF	250V 0.47μF	250V 0.47μF	250V 0.47μF
4	C4	Film capacitor	250V 0.47μF	250V 0.47μF	—	—
5	C5	Ceramic capacitor	400V 2200PF	400V 1000PF	400V 2200PF	—
6	C6	Ceramic capacitor	400V 2200PF	400V 1000PF	400V 2200PF	—
7	C7	Ceramic capacitor	400V 1000PF	400V 1000PF	400V 1000PF	400V 1000PF
8	L1	Choke coil	8A 190μH	8A 30μH	8A 190μH	8A 190μH
9	L2	Choke coil	8A 190μH	8A 30μH	8A 190μH	8A 190μH
10	L3	Common mode choke	10A 3mH(*1)	10A 3mH(*1)	10A 3mH(*1)	10A 3mH(*1)
11	L4	Common mode choke	10A 3mH(*1)	10A 3mH(*1)	—	—

★1: Leakage inductance 30μH or more

Table 15.1.2 Recommended parts list(100VAC, 500W)

No.	Product name	Rating	Model	Manufacturer
1	Film capacitor	250V 0.47μF	CFKC22E474M	Nitsuko
2	Ceramic capacitor	400V 2200PF	DE7100F222MVA1 · KC	Murata
3	Ceramic capacitor	400V 1000PF	DE7090B102MVA1 · KC	Murata
4	Choke coil	8A 190μH	CM08191G7	Nippon Chemi-Con
5	Choke coil	8A 30μH	CM08300D4	Nippon Chemi-Con
6	Common mode choke	10A 3mH(*1)	5MF-10-3	Nippon Chemi-Con

② Recommended circuit constants for 100VAC, 250W

Table 15.2.1 Table of constants(100VAC, 250W)

No.	Standard		VCCI・B CISPR22-B	VCCI・A	FCC・B	FCC・A
	Symbol	Product name				
1	C1	Film capacitor	250V 0.47 μ F	250V 0.47 μ F	250V 0.47 μ F	250V 0.47 μ F
2	C2	Film capacitor	250V 0.47 μ F	250V 0.47 μ F	250V 0.47 μ F	250V 0.47 μ F
3	C3	Film capacitor	250V 0.47 μ F	250V 0.47 μ F	250V 0.47 μ F	250V 0.47 μ F
4	C4	Film capacitor	250V 0.47 μ F	250V 0.47 μ F	—————	—————
5	C5	Ceramic capacitor	400V 2200PF	400V 1000PF	400V 2200PF	—————
6	C6	Ceramic capacitor	400V 2200PF	400V 1000PF	400V 2200PF	—————
7	C7	Ceramic capacitor	400V 1000PF	400V 1000PF	400V 1000PF	400V 1000PF
8	L1	Choke coil	4A 200 μ H	4A 45 μ H	4A 200 μ H	4A 200 μ H
9	L2	Choke coil	4A 200 μ H	4A 45 μ H	4A 200 μ H	4A 200 μ H
10	L3	Common mode choke	5A 3mH(*1)	5A 3mH(*1)	5A 3mH(*1)	5A 3mH(*1)
11	L4	Common mode choke	5A 3mH(*1)	5A 3mH(*1)	—————	—————

*1: Leakage inductance 30 μ H or more

Table 15.2.2 Recommended parts list(100VAC, 250W)

No.	Product name	Rating	Model	Manufacturer
1	Film capacitor	250V 0.47 μ F	CFKC22E474M	Nitsuko
2	Ceramic capacitor	400V 2200PF	DE7100F222MVA1・KC	Murata
3	Ceramic capacitor	400V 1000PF	DE7090B102MVA1・KC	Murata
4	Choke coil	4A 200 μ H	CM04201G3	Nippon Chemi-Con
5	Choke coil	4A 45 μ H	TM04450N2	Nippon Chemi-Con
6	Common mode choke	5A 3mH(*1)	5MF-5-3	Nippon Chemi-Con

③ Recommended circuit constants for 200VAC, 750W

Table 15.3.1 Table of constants(200VAC, 750W)

No.	Standard		VCCI・B CISPR22-B	VCCI・A	FCC・B	FCC・A
	Symbol	Product name				
1	C1	Film capacitor	250V 0.47 μ F	250V 0.47 μ F	250V 0.47 μ F	250V 0.47 μ F
2	C2	Film capacitor	250V 0.47 μ F	250V 0.47 μ F	250V 0.47 μ F	250V 0.47 μ F
3	C3	Film capacitor	250V 0.47 μ F	250V 0.47 μ F	250V 0.47 μ F	250V 0.47 μ F
4	C4	Film capacitor	250V 0.47 μ F	250V 0.47 μ F	—————	—————
5	C5	Ceramic capacitor	400V 2200PF	400V 1000PF	400V 2200PF	—————
6	C6	Ceramic capacitor	400V 2200PF	400V 1000PF	400V 2200PF	—————
7	C7	Ceramic capacitor	400V 1000PF	400V 1000PF	400V 1000PF	400V 1000PF
8	L1	Choke coil	6A 200 μ H	5A 30 μ H	6A 200 μ H	6A 200 μ H
9	L2	Choke coil	6A 200 μ H	5A 30 μ H	6A 200 μ H	6A 200 μ H
10	L3	Common mode choke	5A 3mH(*1)	5A 3mH(*1)	5A 3mH(*1)	5A 3mH(*1)
11	L4	Common mode choke	5A 3mH(*1)	5A 3mH(*1)	—————	—————

*1: Leakage inductance 30 μ H or more

Table 15.3.2 Recommended parts list(200VAC, 750W)

No.	Product name	Rating	Model	Manufacturer
1	Film capacitor	250V 0.47 μ F	CFKC22E474M	Nitsuko
2	Ceramic capacitor	400V 2200PF	DE7100F222MVA1・KC	Murata
3	Ceramic capacitor	400V 1000PF	DE7090B102MVA1・KC	Murata
4	Choke coil	6A 200 μ H	CM06201G7	Nippon Chemi-Con
5	Choke coil	5A 30 μ H	TM05300N4	Nippon Chemi-Con
6	Common mode choke	5A 3mH(*1)	5MF-5-3	Nippon Chemi-Con

④ Recommended circuit constants for 200VAC, 500W

Table 15.4.1 Table of constants(200VAC, 500W)

No.	Standard		VCCI・B CISPR22-B	VCCI・A	FCC・B	FCC・A
	Symbol	Product name				
1	C1	Film capacitor	250V 0.47 μ F	250V 0.47 μ F	250V 0.47 μ F	250V 0.47 μ F
2	C2	Film capacitor	250V 0.47 μ F	250V 0.47 μ F	250V 0.47 μ F	250V 0.47 μ F
3	C3	Film capacitor	250V 0.47 μ F	250V 0.47 μ F	250V 0.47 μ F	250V 0.47 μ F
4	C4	Film capacitor	250V 0.47 μ F	250V 0.47 μ F	—————	—————
5	C5	Ceramic capacitor	400V 2200PF	400V 1000PF	400V 2200PF	—————
6	C6	Ceramic capacitor	400V 2200PF	400V 1000PF	400V 2200PF	—————
7	C7	Ceramic capacitor	400V 1000PF	400V 1000PF	400V 1000PF	400V 1000PF
8	L1	Choke coil	4A 200 μ H	4A 45 μ H	4A 200 μ H	4A 200 μ H
9	L2	Choke coil	4A 200 μ H	4A 45 μ H	4A 200 μ H	4A 200 μ H
10	L3	Common mode choke	5A 3mH(*1)	5A 3mH(*1)	5A 3mH(*1)	5A 3mH(*1)
11	L4	Common mode choke	5A 3mH(*1)	5A 3mH(*1)	—————	—————

*1: Leakage inductance 30 μ H or more

Table 15.4.2 Recommended parts list(200VAC, 500W)

No.	Product name	Rating	Model	Manufacturer
1	Film capacitor	250V 0.47 μ F	CFKC22E474M	Nitsuko
2	Ceramic capacitor	400V 2200PF	DE7100F222MVA1・KC	Murata
3	Ceramic capacitor	400V 1000PF	DE7090B102MVA1・KC	Murata
4	Choke coil	4A 200 μ H	CM04201G3	Nippon Chemi-Con
5	Choke coil	4A 45 μ H	TM04450N2	Nippon Chemi-Con
6	Common mode choke	5A 3mH(*1)	5MF-5-3	Nippon Chemi-Con

⑤ Recommended circuit constants for 200VAC, 250W

Table 15.5.1 Table of constants(200VAC, 250W)

No.	Standard		VCCI・B CISPR22-B	VCCI・A	FCC・B	FCC・A
	Symbol	Product name				
1	C1	Film capacitor	250V 0.47 μ F	250V 0.47 μ F	250V 0.47 μ F	250V 0.47 μ F
2	C2	Film capacitor	250V 0.47 μ F	250V 0.47 μ F	250V 0.47 μ F	250V 0.47 μ F
3	C3	Film capacitor	250V 0.47 μ F	250V 0.47 μ F	250V 0.47 μ F	250V 0.47 μ F
4	C4	Film capacitor	250V 0.47 μ F	250V 0.47 μ F	—————	—————
5	C5	Ceramic capacitor	400V 2200PF	400V 1000PF	400V 2200PF	—————
6	C6	Ceramic capacitor	400V 2200PF	400V 1000PF	400V 2200PF	—————
7	C7	Ceramic capacitor	400V 1000PF	400V 1000PF	400V 1000PF	400V 1000PF
8	L1	Choke coil	2A 200 μ H	2A 100vH	2A 200 μ H	2A 200 μ H
9	L2	Choke coil	2A 200 μ H	2A 100vH	2A 200 μ H	2A 200 μ H
10	L3	Common mode choke	2A 3mH(*1)	2A 3mH(*1)	2A 3mH(*1)	2A 3mH(*1)
11	L4	Common mode choke	2A 3mH(*1)	2A 3mH(*1)	—————	—————

*1: Leakage inductance 30 μ H or more

Table 15.5.2 Recommended parts list(200VAC, 250W)

No.	Product name	Rating	Model	Manufacturer
1	Film capacitor	250V 0.47 μ F	CFKC22E474M	Nitsuko
2	Ceramic capacitor	400V 2200PF	DE7100F222MVA1・KC	Murata
3	Ceramic capacitor	400V 1000PF	DE7090B102MVA1・KC	Murata
4	Choke coil	2A 200 μ H	CM02201N2	Nippon Chemi-Con
5	Choke coil	2A 100 μ H	TM02101N2	Nippon Chemi-Con
6	Common mode choke	2A 3mH(*1)	5MF-2-3	Nippon Chemi-Con

16 Selection of Output Filtering Capacitor

Since the unit does not have a built-in output filtering capacitor, install one externally to the output pins.

Follow the guidelines below to select an electrolytic capacitor with an appropriate capacitance and ripple current rating considering the output ripple voltage, hold-up time and life. The capacity should be selected between 120 and 1,000 μ F. Avoid connecting the capacity above 1,000 μ F to output, it may severely damage the unit.

(1)Output ripple voltage

Obtain the required capacity from the output ripple voltage. Make sure that the output ripple voltage is below 15VP-P.

$$C_o \geq \frac{P_o}{2\pi f \times V_{rpl} \times V_o} \quad \text{----- (1)}$$

- C_o : Capacitance of the output filtering capacitor [F]
- V_{rpl} : Output ripple voltage [VP-P]
- P_o : DPA500F-360 output power [W]
- f : Input frequency (50Hz/60Hz) [Hz]
- V_o : Output voltage (Refer to Fig.16.1) [V]

(2)Hold-up time

Obtain the required capacity from the hold-up time required for the system.

$$C_o \geq \frac{2 \times P_o \times T_h}{(V_o - V_{rpl}/2)^2 - V_{min}^2} \quad \text{----- (2)}$$

- T_h : Hold-up time [s]
- P_o : DPA500F-360 output wattage [W]
- V_o : Output voltage (Refer to Fig.16.1) [V]
- V_{rpl} : Output ripple voltage [VP-P]
- V_{min} : Minimum input voltage of DC-DC converter

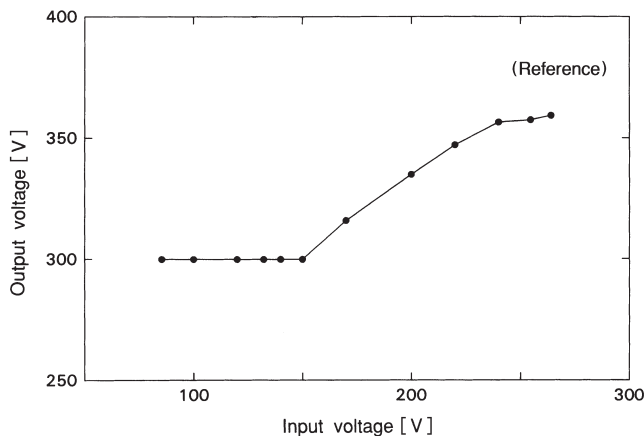

Fig.16.1 Output voltage (Actually measured data)

(3)Ripple current

Obtain the ripple current for low frequency and high frequency from Fig.16.2. Use Formula (3) to calculate the total ripple current. Use a capacitor with the ripple current rating above the resulting value. Since the correction factor of allowable ripple current frequency (K) varies depending on the capacitor, check the exact value in the catalog of the capacitor.

$$I_r = \sqrt{I_L^2 + (I_H/K)^2} \quad \text{----- (3)}$$

- I_r : Ripple current flowing into the output filtering capacitor [Arms]
- I_L : Low frequency ripple current (Refer to Fig.16.2) [Arms]
- I_H : High frequency ripple current (Refer to Fig.16.2) [Arms]
- K : Correction factor of the allowable ripple current frequency

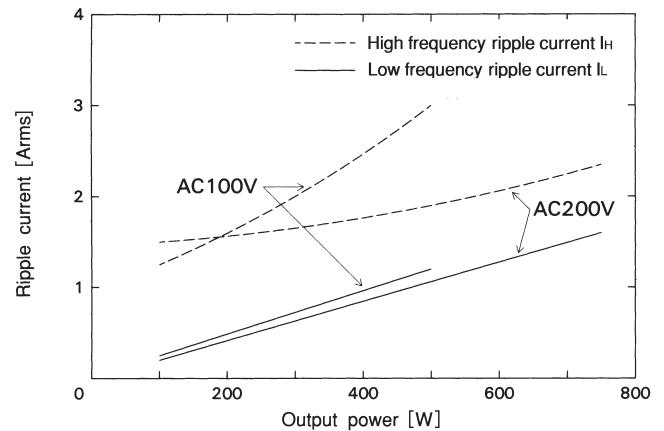

Fig.16.2 Output ripple current

(4)Selection of electrolytic capacitor

Use the electrolytic capacitor which meets the capacitance calculated in (1) and (2) above and the ripple current rating obtained in (3). When selecting the electrolytic capacitor, take into consideration the tolerance of the capacitor. Note that an electrolytic capacitor has a limited lifetime. The lifetime of the electrolytic capacitor is determined by the capacitor temperature, which can be estimated by the Formula (4) below. To improve the reliability of the system, select an electrolytic capacitor which has a long enough lifetime (L_o).

$$L_x = L_o \times 2^{\frac{T_o - T_x}{10}} \quad \text{----- (4)}$$

- L_x : Estimated lifetime [H]
- L_o : Guaranteed lifetime of the electrolytic capacitor [H]
- T_o : Maximum rated operating temperature L_o [°C]
- T_x : Electrolytic capacitor temperature for use [°C]

17 Connection to Back-End Units

The following illustrates the permitted connection of DPA500F-360 to the back-end units from our products and the precautions for connection.

(1) Connection to DAS Series

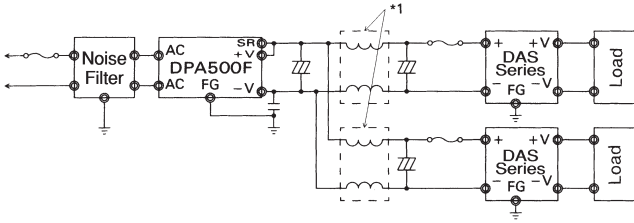

Fig.17.1 Connection to the DAS Series

*1 Depending on the required noise standard, installation of a noise filter may be necessary. Especially, when long wires are used, it is recommended to install noise filters to reduce the RF noise. Refer to Section 11 when controlling the start/stop of the DAS Series using the PR or IOG signal of DPA500F.

(2) Connection to the Back-End Units other than the DAS Series

DPA500F can also be connected to the back-end units listed in Table 17.1 and 17.2.

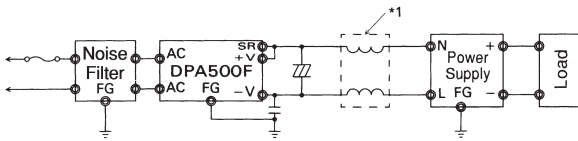

Fig.17.2 Connection to the Back-End unit other than DAS Series

*1 Depending on the required noise standard, installation of a noise filter may be necessary. Especially, when long wires are used, it is recommended to install noise filters to reduce the radiation noise.

Table 17.1 Allowed connection to DPA500F

No.	AC input specification	Model
1	AC85 - 264V Universal input voltage	P15, 30 PMC15, 30 LDA10, 15, 30, 50, 75 LDC15, 30, 60
2	AC170 - 264V AC200V input	AD960
3	AC85 - 132/170 - 264V User selectable input voltage	P50, 100, 150, 1500 PMC50, 75, 100 AD240, 480

No.	Connection	Notes
1	YES	
2	YES	
3	YES	Set input selection to AC200V Caution: The unit will be damaged if set to AC100V

Basic Characteristics Data

Model	Circuit method	Switching frequency [kHz]	Input current [A]	Rated input fuse	Inrush current protection	PCB/Pattern			Series/Parallel operation availability	
						Material	Single sided	Double sided	Series operation	Parallel operation
DPA500F	Active filter	170	5.6 *1	-	SCR	Aluminum	Yes		No	Yes
			4.0 *2							

*1 The value of input current is at ACIN100V and 500W load.

*2 The value of input current is at ACIN200V and 750W load.