



Data Sheet



MegaMod & MegaMod Jr. Family

25 to 600 Watts DC-DC Converters

Single, Dual, Triple Output Chassis Mount



Features

- RoHS compliant (VE versions)
- Inputs: 10 to 400 Vdc
- Any output, 1 to 95 Vdc
- cULus, cTUVus, CE Marked
- 80 – 90% Efficiency (Typical)
- Up to 27 W/In³
- 1 Up:
 - 2.58" x 2.5" x 0.62" (Junior)
 - 4.9" x 2.5" x 0.62" (Full Size)
- 2 Up:
 - 2.58" x 4.9" x 0.62" (Junior)
 - 4.9" x 4.9" x 0.62" (Full Size)
- 3 Up:
 - 2.58" x 7.3" x 0.62" (Junior)
 - 4.9" x 7.3" x 0.62" (Full Size)
- Low noise ZCS power architecture
- Booster versions available for expanded output power – full size only (add B to part number Example: VI-LBxx-xx)

Product Highlights

Vicor's MegaMod and MegaMod Jr. Families of single, dual and triple output DC-DC converters provide power system designers with cost effective, high performance, off-the-shelf solutions to applications that might otherwise require a custom supply.

Incorporating standard VI-200 or VI-J00 Family converters in rugged, chassis mount packages, MegaMod and MegaMod Jr.'s can be ordered with single, dual or triple outputs, having a combined output power of up to 600 W. Totally isolated outputs eliminate efficiency penalties and output interaction problems.

Configuration Chart

Substitute VE- for VI- for RoHS compliant versions					
Full-Size Modules – MegaMod			Junior-Size Modules – MegaMod Jr		
Configuration	Output Power	# of Modules	Configuration	Output Power	# of Modules
Single Output			Single Output		
VI-L [] [] - [] [] []	50 – 200 W	1	VI-LJ [] [] - [] [] []	25 – 100 W	1
VI-M [] [] - [] [] []	100 – 400 W	2			
VI-N [] [] - [] [] []	300 – 600 W	3			
Dual Output			Dual Output		
VI-P [] [] - [] [] [] []	100 – 400 W	2	VI-PJ [] [] - [] [] [] []	50 – 200 W	2
VI-Q [] [] - [] [] [] []	150 – 600 W	3			
Triple Output			Triple Output		
VI-R [] [] - [] [] [] [] []	150 – 600 W	3	VI-RJ [] [] - [] [] [] [] []	75 – 300 W	3

Input Voltage

Nominal	Input Range Full Power	Maximum Power ^(a) (see chart below)		Low Line 75% Max Power	Transient ^[a]
		MegaMod	MegaMod Jr.		
0 = 12 V ^[b]	10 – 20 V	(4)	(1)	n/a	22
V = 24 V ^[b]	10 – 36 V	(2)	(11)	n/a	n/a
1 = 24 V ^[b]	21 – 32 V	(8)	(5)	18 V	36
W = 24 V ^[b]	18 – 36 V	(8)	(5)	n/a	n/a
2 = 36 V	21 – 56 V	(6)	(1)	18 V	60
3 = 48 V	42 – 60 V	(10)	(5)	36 V	72
N = 48 V	36 – 76 V	(10)	(5)	n/a	n/a
4 = 72 V	55 – 100 V	(9)	(4)	45 V	110
T = 110 V	66 – 160 V	(8)	(5)	n/a	n/a
5 = 150 V	100 – 200 V	(9)	(5)	85 V	215
6 = 300 V	200 – 400 V	(10)	(6)	170 V	425
7 = 150/300 V	100 – 375 V	(5)	(1)	90 V	n/a

Max. Output Per Module	5 – 7.5 V Outputs	>7.5 V Outputs	<5 V Outputs
(1)	50 W	75 W	10 A
(2)	50 W ^[c]	75 W	15 A
(4)	75 W	75 W	15 A
(5)	75 W	100 W	20 A
(6)	100 W	100 W	20 A
(7)	100 W	150 W	30 A
(8)	150 W	150 W	30 A
(9)	150 W	200 W	40 A
(10)	200 W	200 W	40 A
(11)	50 W	50 W	10 A

Output Voltage

Z = 2 V
Y = 3.3 V
O = 5 V
X = 5.2 V
W = 5.5 V
V = 5.8 V
T = 6.5 V
R = 7.5 V
M = 10 V
1 = 12 V
P = 13.8 V
2 = 15 V
N = 18.5 V
3 = 24 V
L = 28 V
J = 36 V
K = 40 V
4 = 48 V
H = 52 V
F = 72 V
D = 85 V
B = 95 V

[a] Transient voltage for 1 second.

[b] Total MegaMod output power for 225 W, "0", "V" input models and 450 W, "1", "W" input models are limited to 55°C ambient, and are available by special order.

[c] 7.5 V output is 75 W

Product Grade Temperature (°C)

MegaMod	MegaMod Jr.
E = -10 to +85	-10 to +100
C = -25 to +85	-25 to +100
I = -40 to +85	-40 to +100
M = -55 to +85	-55 to +100

Refers to Baseplate Temperature

Output Power/Current

Vout ≥ 5 V	Vout < 5 V
W = 100 W	W = 20 A
V = 150 W	V = 30 A
U = 200 W	U = 40 A
S = 300 W	S = 60 A
Q = 400 W	Q = 80 A

Output Power/Current

MegaMod		MegaMod Jr.	
Vout ≥ 5 V	Vout < 5 V	Vout ≥ 5 V	Vout < 5 V
Y = 50 W	Y = 10 A	Z = 25 W	Z = 5 A
X = 75 W	X = 15 A	Y = 50 W	Y = 10 A
W = 100 W	W = 20 A	X = 75 W	X = 15 A
V = 150 W	V = 30 A	W = 100 W	W = 20 A
U = 200 W	U = 40 A		

Output Power/Current

Vout ≥ 5 V	Vout < 5 V
S = 300 W	S = 60 A
P = 450 W	P = 90 A
M = 600 W	M = 120 A

MEGAMOD SPECIFICATIONS

(typical at $T_{BP} = 25^{\circ}\text{C}$, nominal line, 75% load, unless otherwise specified)

INPUT SPECIFICATIONS

Parameter	MegaMod (E-Grade)			MegaMod (C-, I-, M-Grade)			Unit	Test Conditions
	Min	Typ	Max	Min	Typ	Max		
Inrush charge		120x10 ⁻⁶			120x10 ⁻⁶	200x10 ⁻⁶	Coulombs	Nom. line, per module
Input reflected ripple current – pp		10%			10%		I _{IN}	Nom. line, full load
Input ripple rejection		25+20Log($\frac{V_{in}}{V_{out}}$)			30+20Log($\frac{V_{in}}{V_{out}}$)		dB	120 Hz, nom. line
					20+20Log($\frac{V_{in}}{V_{out}}$)		dB	2400 Hz, nom. line
No load power dissipation		1.35	2		1.35	2	Watts	Per module

OUTPUT SPECIFICATIONS

Parameter	MegaMod (E-Grade)			MegaMod (C-, I-, M-Grade)			Units	Test Conditions
	Min	Typ	Max	Min	Typ	Max		
Setpoint accuracy		1%	2%		0.5%	1%	V _{NOM}	
Load / line regulation			0.5%		0.05%	0.2%	V _{NOM}	LL to HL, 10% to FL
			1%		0.2%	0.5%	V _{NOM}	LL to HL, NL to 10%
Output temperature drift		0.02			0.01	0.02	% / °C	Over rated temp.
Long term drift		0.02			0.02		%/1K hours	
Output ripple - pp								
2 V, 3.3 V			150		60	100	mV	20 MHz bandwidth
5 V			5%		2%	3%	V _{NOM}	20 MHz bandwidth
10 – 95 V			3%		0.75%	1.5%	V _{NOM}	20 MHz bandwidth
Output voltage trimming ^[a]	50%		110%	50%		110%	V _{NOM}	
Total remote sense compensation	0.5			0.5			Volts	0.25 V max. neg. leg
OVP setpoint ^[b]		125%		115%	125%	135%	V _{NOM}	Recycle power
Current limit	105%		135%	105%		125%	I _{NOM}	Automatic restart
Short circuit current ^[c]	20%		140%	20%		130%	I _{NOM}	

^[a] 10 V, 12 V and 15 V outputs, standard trim range $\pm 10\%$. Consult factory for wider trim range. 95 V_{out} cannot be trimmed up.

^[b] 131% typical for booster modules.

^[c] Output voltages of 5 V or less incorporate foldback current limiting; outputs of 10 V and above contain straight-line limiting.

CONTROL PIN SPECIFICATIONS

Parameter	MegaMod (E-Grade)			MegaMod (C-, I-, M-Grade)			Units	Test Conditions
	Min	Typ	Max	Min	Typ	Max		
Gate out impedance		50			50		Ohms	
Gate in impedance		10 ³			10 ³		Ohms	
Gate in open circuit voltage		6			6		Volts	Use open collector
Gate in low threshold	0.65			0.65			Volts	
Gate in low current			6			6	mA	
Power sharing accuracy	0.95		1.05	0.95		1.05		

MEGAMOD SPECIFICATIONS (cont.)

■ DIELECTRIC WITHSTAND CHARACTERISTICS

Parameter	MegaMod (E-Grade)			MegaMod (C-, I-, M-Grade)			Unit	Test Conditions
	Min	Typ	Max	Min	Typ	Max		
Input to output	3,000			3,000			VRMS	Baseplate earthed
Output to baseplate	500			500			VRMS	
Input to baseplate	1,500			1,500			VRMS	

■ THERMAL CHARACTERISTICS

Parameter	MegaMod (E-Grade)			MegaMod (C-, I-, M-Grade)			Units	Test Conditions
	Min	Typ	Max	Min	Typ	Max		
Efficiency		78-88%			80 – 90%			
Baseplate to chassis		0.1			0.1		°C/Watt	
Thermal Shutdown (drivers only)	90	95	105	90	95	105	°C	Baseplate (Cool and recycle power to restart)

■ MECHANICAL SPECIFICATIONS

Parameter	MegaMod (E-Grade)			MegaMod (C-, I-, M-Grade)			Units	Test Conditions
	Min	Typ	Max	Min	Typ	Max		
Weight								
1 Up		9.0 (255)			9.0 (255)		Ounces (Grams)	
2 Up		1.2 (545)			1.2 (545)		Lbs. (Grams)	
3 Up		1.7 (772)			1.7 (772)		Lbs. (Grams)	

MEGAMOD JR. SPECIFICATIONS

(typical at $T_{BP} = 25^{\circ}\text{C}$, nominal line, 75% load, unless otherwise specified)

INPUT SPECIFICATIONS

Parameter	MegaMod Jr. (E-Grade)			MegaMod Jr. (C-, I-, M-Grade)			Unit	Test Conditions
	Min	Typ	Max	Min	Typ	Max		
Inrush charge		60×10^{-6}	100×10^{-6}		60×10^{-6}	100×10^{-6}	Coulombs	Nom. line, per module
Input reflected ripple current — pp		10%			10%		IIN	Nom. line, full load
Input ripple rejection		$25 + 20 \text{Log} \left(\frac{V_{in}}{V_{out}} \right)$			$30 + 20 \text{Log} \left(\frac{V_{in}}{V_{out}} \right)$		dB	120 Hz, nom. line
					$20 + 20 \text{Log} \left(\frac{V_{in}}{V_{out}} \right)$		dB	2400 Hz, nom. line
No load power dissipation		1.35	2		1.35	2	Watts	Per module

OUTPUT SPECIFICATIONS

Parameter	MegaMod Jr. (E-Grade)			MegaMod Jr. (C-, I-, M-Grade)			Units	Test Conditions
	Min	Typ	Max	Min	Typ	Max		
Setpoint accuracy		1.0%	2.0%		0.5%	1%	VNOM	
Load/line regulation			0.5%		0.05%	0.2%	VNOM	LL to HL, 10% to FL
			1.0%		0.2%	0.5%	VNOM	LL to HL, NL to 10%
Output temperature drift		0.02			0.01		%/°C	Over rated temp.
Long term drift		0.02			0.02		%/1K hours	
Output ripple, pp								
2 V, 3.3 V		200			100	150	mV	20 MHz bandwidth
5 V		5%			2%	3%	VNOM	20 MHz bandwidth
10 V – 95 V		3%			0.75%	1.5%	VNOM	20 MHz bandwidth
Output voltage trimming ^[a]	50%		110%	50%		110%	VNOM	
Total remote sense compensation	0.5			0.5			Volts	0.25V max. neg. leg
OVP setpoint		N/A			N/A			
Current limit	105%		135%	105%		125%	INOM	Automatic restart
Short circuit current	105%		140%	105%		130%	INOM	

^[a] 10 V, 12 V and 15 V outputs, standard trim range $\pm 10\%$. Consult factory for wider trim range. 95 Vout cannot be trimmed up.

CONTROL PIN SPECIFICATIONS

Parameter	MegaMod Jr. (E-Grade)			MegaMod Jr. (C-, I-, M-Grade)			Units	Test Conditions
	Min	Typ	Max	Min	Typ	Max		
Gate out impedance		50			50		Ohms	
Gate in impedance		1,000			1,000		Ohms	
Gate in high threshold		6			6		Volts	Use open collector
Gate in low threshold	0.65			0.65			Volts	
Gate in low current			6			6	mA	

MEGAMOD JR. SPECIFICATIONS (cont.)

■ DIELECTRIC WITHSTAND CHARACTERISTICS

Parameter	MegaMod Jr. (E-Grade)			MegaMod Jr. (C-, I-, M-Grade)			Unit	Test Conditions
	Min	Typ	Max	Min	Typ	Max		
Input to output	3,000			3,000			VRMS	Baseplate earthed
Output to baseplate	500			500			VRMS	
Input to baseplate	1,500			1,500			VRMS	

■ THERMAL CHARACTERISTICS

Parameter	MegaMod Jr. (E-Grade)			MegaMod Jr. (C-, I-, M-Grade)			Units	Test Conditions
	Min	Typ	Max	Min	Typ	Max		
Efficiency		78 – 88%			80 – 90%			
Baseplate to chassis		0.2			0.2		°C/Watt	

■ MECHANICAL SPECIFICATIONS

Parameter	MegaMod Jr. (E-Grade)			MegaMod Jr. (C-, I-, M-Grade)			Units	Test Conditions
	Min	Typ	Max	Min	Typ	Max		
Weight								
1 Up		4.5 (127)			4.5 (127)		Ounces (Grams)	
2 Up		8.8 (250)			8.8 (250)		Ounces (Grams)	
3 Up		13.3 (377)			13.3 (377)		Ounces (Grams)	

MEGAMOD MECHANICAL SPECIFICATIONS

Inputs	
1 -Input	5 Gate Out #2
2 Gate Out #1	6 Gate In #2
3 Gate In #1	7 Gate Out #3
4 +Input	8 Gate In #3

Outputs		
Output #1	Output #2	Output #3
A -Output	F -Output	L -Output
B -Sense*	G -Sense	M -Sense
C Trim*	H Trim	N Trim
D +Sense*	J +Sense	P +Sense
E +Output	K +Output	Q +Output

*For Units with BatMod
 B-IMON
 C-ITRIM
 D-VTRIM

Inputs Outputs

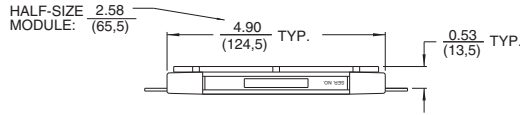

Side view (all models)

L- and LJ-Series L- and LJ-Series

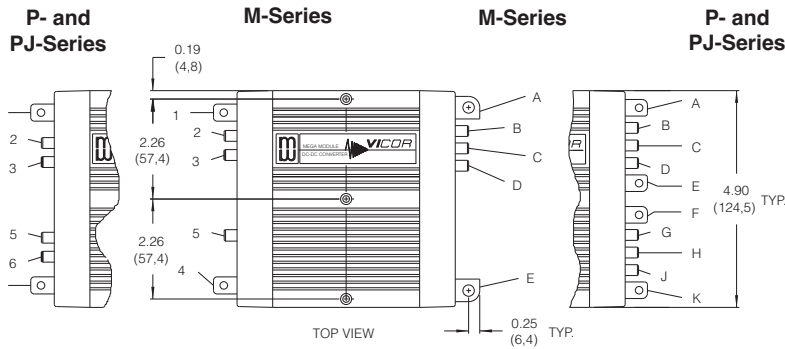
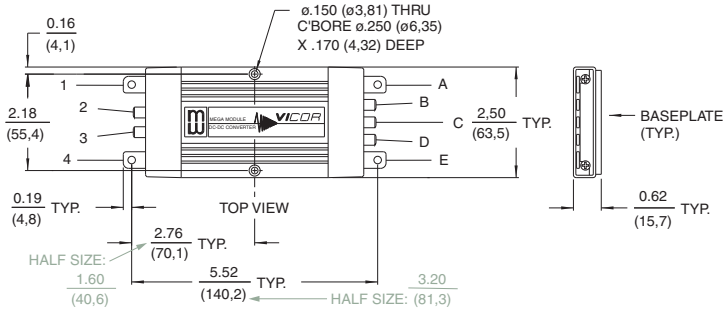

Mounting Information
 Use #6 machine hardware torqued to 5-7 in-lbs.

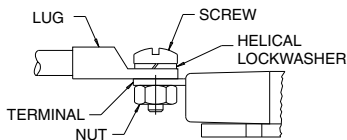
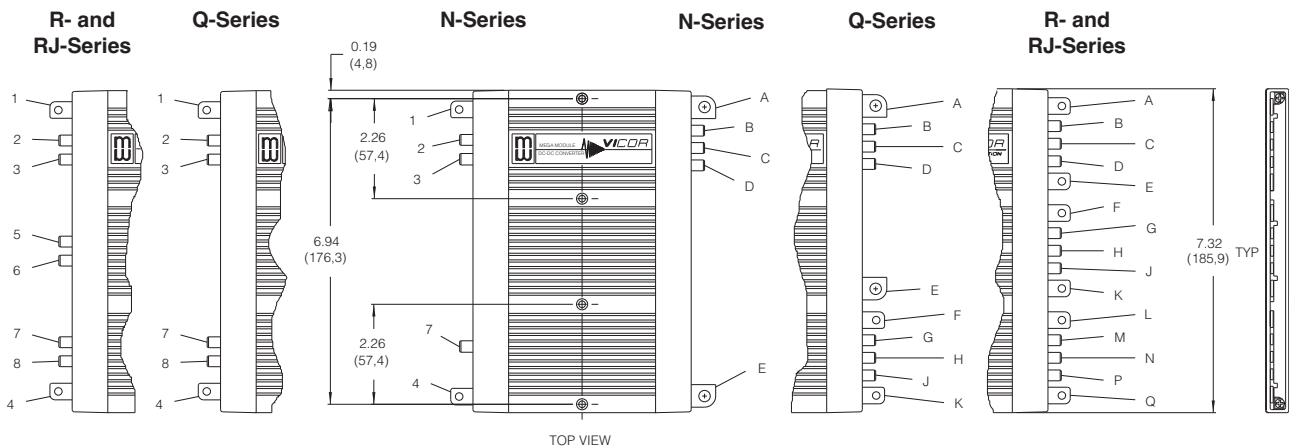

Terminal and Product Model	Terminal Style	Screw Size	Recommended Torque
-Input, +Input All models	PCB	8-32 UNC	10 in-lb (1.1 N-m)
-Output, +Output L-, P-, R-, LJ-, PJ- & RJ-Series	PCB	8-32 UNC	10 in-lb (1.1 N-m)
M- & N-Series	Metal	1/4-20 UNC	65 in-lb (7.2 N-m)
Q-Series	PCB	8-32 UNC	10 in-lb (1.1 N-m)
Supervisory All models	Metal	1/4-20 UNC	65 in-lb (7.2 N-m)

Sized to accept AMP Faston® insulated receptacle #2-520184-2

Warranty

Vicor products are guaranteed for two years from date of shipment against defects in material or workmanship when in normal use and service. This warranty does not extend to products subjected to misuse, accident, or improper application or maintenance. Vicor shall not be liable for collateral or consequential damage. This warranty is extended to the original purchaser only.

EXCEPT FOR THE FOREGOING EXPRESS WARRANTY, VICOR MAKES NO WARRANTY, EXPRESS OR IMPLIED, INCLUDING, BUT NOT LIMITED TO, THE WARRANTY OF MERCHANTABILITY OR FITNESS FOR A PARTICULAR PURPOSE.

Vicor will repair or replace defective products in accordance with its own best judgement. For service under this warranty, the buyer must contact Vicor to obtain a Return Material Authorization (RMA) number and shipping instructions. Products returned without prior authorization will be returned to the buyer. The buyer will pay all charges incurred in returning the product to the factory. Vicor will pay all reshipment charges if the product was defective within the terms of this warranty.

Information published by Vicor has been carefully checked and is believed to be accurate; however, no responsibility is assumed for inaccuracies. Vicor reserves the right to make changes to any products without further notice to improve reliability, function, or design. Vicor does not assume any liability arising out of the application or use of any product or circuit; neither does it convey any license under its patent rights nor the rights of others. Vicor general policy does not recommend the use of its components in life support applications wherein a failure or malfunction may directly threaten life or injury. Per Vicor Terms and Conditions of Sale, the user of Vicor components in life support applications assumes all risks of such use and indemnifies Vicor against all damages.

Vicor's comprehensive line of power solutions includes high density AC-DC and DC-DC modules and accessory components, fully configurable AC-DC and DC-DC power supplies, and complete custom power systems.

Information furnished by Vicor is believed to be accurate and reliable. However, no responsibility is assumed by Vicor for its use. Vicor components are not designed to be used in applications, such as life support systems, wherein a failure or malfunction could result in injury or death. All sales are subject to Vicor's Terms and Conditions of Sale, which are available upon request.

Specifications are subject to change without notice.

Intellectual Property Notice

Vicor and its subsidiaries own Intellectual Property (including issued U.S. and Foreign Patents and pending patent applications) relating to the products described in this data sheet. Interested parties should contact Vicor's Intellectual Property Department.

Vicor Corporation
25 Frontage Road
Andover, MA, USA 01810
Tel: 800-735-6200
Fax: 978-475-6715

email

Customer Service: custserv@vicorpower.com
Technical Support: apps@vicorpower.com