

**PKM4000B series Intermediate Bus Converters**  
 Input 36-75 V, Output up to 33 A / 380 W

EN/LZT 146 305 R6B June 2010

© Ericsson AB

**Key Features**

- Industry standard Quarter-brick  
 57.9 x 36.8 x 11.6 mm (2.28 x 1.45 x 0.46 in.)
- High efficiency, typ. 96 % at 12 Vout 50% load & 48Vin
- 1500 Vdc input to output isolation
- Meets safety requirements according to IEC/EN/UL 60950
- More than 1.1 million hours MTBF

**General Characteristics**

- N+1 parallelable
- Input under voltage protection
- Over temperature protection
- Output over voltage protection
- Output short-circuit protection
- Remote control
- SMD option with low profile 11.2mm
- Optional latching OTP, OVP
- Optional baseplate
- Optional case to ground pin (only with baseplate)
- Highly automated manufacturing ensures quality
- ISO 9001/14001 certified supplier



**Safety Approvals**



E210157

**Design for Environment**



Meets requirements in high-temperature lead-free soldering processes.

**Contents**

Ordering Information	2
General Information	2
Safety Specification	3
Absolute Maximum Ratings	4
Electrical Specification	
12V, 25A / 290W	PKM4204B PI 5
12V, 33A / 380W	PKM4304B 9
EMC Specification	13
Operating Information	14
Thermal Consideration	16
Connections	17
Mechanical Information	18
Soldering Information	21
Delivery Information	22
Product Qualification Specification	24

**PKM4000B series Intermediate Bus Converters**  
 Input 36-75 V, Output up to 33 A / 380 W

EN/LZT 146 305 R6B June 2010

© Ericsson AB

**Ordering Information**

Product program	Output
PKM4304B	12 V, 33 A / 380 W
PKM4204B PI	12 V, 25 A / 290 W

Product number and Packaging

PKM4304B n <sub>1</sub> n <sub>2</sub> n <sub>3</sub> n <sub>4</sub> n <sub>5</sub> n <sub>6</sub>							
Options	n <sub>1</sub>	n <sub>2</sub>	n <sub>3</sub>	n <sub>4</sub>	n <sub>5</sub>	n <sub>6</sub>	
Mounting option	o						
Remote control logic		o					
Baseplate			o				
Case to ground pin				o			
Latching protections(OTP, OVP)					o		
Pin length							o

Options	Description
n <sub>1</sub>	PI Through hole SI Surface mounting
n <sub>2</sub>	Negative logic* P Positive logic
n <sub>3</sub>	LP Latching protection
n <sub>4</sub>	Open frame * HS Baseplate
n <sub>5</sub>	G Case to ground pin
n <sub>6</sub>	5.33 mm* LA 3.69 mm LB 4.57 mm LC 2.79 mm

Note: (1) Case to ground pin only available with baseplate  
 Note: (2) SMD option only available for PKM4304B series  
 Note: (3) If several options needed below sequence is to be used  
 LOGIC OPTION → LATCHING PROT. → BASEPLATE →  
 CASE GROUND → PIN LENGTH

Example: PKM4304BPIPLPHSGLA

\* Standard variant (i.e. no option selected).

**General Information**

**Reliability**

The Mean Time Between Failure (MTBF) is calculated at full output power and an operating ambient temperature (T<sub>A</sub>) of +40°C, which is a typical condition in Information and Communication Technology (ICT) equipment. Different methods could be used to calculate the predicted MTBF and failure rate which may give different results. Ericsson Power Modules currently uses Telcordia SR332.

Predicted MTBF for the series is:

- 1.1 million hours according to Telcordia SR332, issue 1,

Black box technique.

Telcordia SR332 is a commonly used standard method intended for reliability calculations in ICT equipment. The parts count procedure used in this method was originally modelled on the methods from MIL-HDBK-217F, Reliability Predictions of Electronic Equipment. It assumes that no reliability data is available on the actual units and devices for which the predictions are to be made, i.e. all predictions are based on generic reliability parameters.

**Compatibility with RoHS requirements**

The products are compatible with the relevant clauses and requirements of the RoHS directive 2002/95/EC and have a maximum concentration value of 0.1% by weight in homogeneous materials for lead, mercury, hexavalent chromium, PBB and PBDE and of 0.01% by weight in homogeneous materials for cadmium.

Exemptions in the RoHS directive utilized in Ericsson Power Modules products include:

- Lead in high melting temperature type solder (used to solder the die in semiconductor packages)
- Lead in glass of electronics components and in electronic ceramic parts (e.g. fill material in chip resistors)
- Lead as an alloying element in copper alloy containing up to 4% lead by weight (used in connection pins made of Brass)

**Quality Statement**

The products are designed and manufactured in an industrial environment where quality systems and methods like ISO 9000, 6σ (sigma), and SPC are intensively in use to boost the continuous improvements strategy. Infant mortality or early failures in the products are screened out and they are subjected to an ATE-based final test. Conservative design rules, design reviews and product qualifications, plus the high competence of an engaged work force, contribute to the high quality of our products.

**Warranty**

Warranty period and conditions are defined in Ericsson Power Modules General Terms and Conditions of Sale.

**Limitation of Liability**

Ericsson Power Modules does not make any other warranties, expressed or implied including any warranty of merchantability or fitness for a particular purpose (including, but not limited to, use in life support applications, where malfunctions of product can cause injury to a person's health or life).

**© Ericsson AB 2009**

The information and specifications in this technical specification is believed to be correct at the time of

**PKM4000B series Intermediate Bus Converters**  
Input 36-75 V, Output up to 33 A / 380 W

EN/LZT 146 305 R6B June 2010

© Ericsson AB

publication. However, no liability is accepted for inaccuracies, printing errors or for any consequences thereof. Ericsson AB reserves the right to change the contents of this technical specification at any time without prior notice.

**Safety Specification****General information**

Ericsson Power Modules DC/DC converters and DC/DC regulators are designed in accordance with safety standards IEC/EN/UL60950, *Safety of Information Technology Equipment*.

IEC/EN/UL60950 contains requirements to prevent injury or damage due to the following hazards:

- Electrical shock
- Energy hazards
- Fire
- Mechanical and heat hazards
- Radiation hazards
- Chemical hazards

On-board DC-DC converters and DC/DC regulators are defined as component power supplies. As components they cannot fully comply with the provisions of any Safety requirements without "Conditions of Acceptability". Clearance between conductors and between conductive parts of the component power supply and conductors on the board in the final product must meet the applicable Safety requirements. Certain conditions of acceptability apply for component power supplies with limited stand-off (see Mechanical Information for further information). It is the responsibility of the installer to ensure that the final product housing these components complies with the requirements of all applicable Safety standards and Directives for the final product.

Component power supplies for general use should comply with the requirements in IEC60950, EN60950 and UL60950 "Safety of information technology equipment".

There are other more product related standards, e.g. IEEE802.3af "Ethernet LAN/MAN Data terminal equipment power", and ETS300132-2 "Power supply interface at the input to telecommunications equipment; part 2: DC", but all of these standards are based on IEC/EN/UL60950 with regards to safety.

Ericsson Power Modules DC/DC converters and DC/DC regulators are UL60950 recognized and certified in accordance with EN60950.

The flammability rating for all construction parts of the products meets requirements for V-0 class material according to IEC 60695-11-10.

The products should be installed in the end-use equipment, in accordance with the requirements of the ultimate application. Normally the output of the DC/DC converter is

considered as SELV (Safety Extra Low Voltage) and the input source must be isolated by minimum Double or Reinforced Insulation from the primary circuit (AC mains) in accordance with IEC/EN/UL60950.

**Isolated DC/DC converters**

It is recommended that a slow blow fuse with a rating twice the maximum input current per selected product be used at the input of each DC/DC converter. If an input filter is used in the circuit the fuse should be placed in front of the input filter.

In the rare event of a component problem in the input filter or in the DC/DC converter that imposes a short circuit on the input source, this fuse will provide the following functions:

- Isolate the faulty DC/DC converter from the input power source so as not to affect the operation of other parts of the system.
- Protect the distribution wiring from excessive current and power loss thus preventing hazardous overheating.

The galvanic isolation is verified in an electric strength test. The test voltage ( $V_{iso}$ ) between input and output is 1500 Vdc or 2250 Vdc for 60 seconds (refer to product specification).

Leakage current is less than 1  $\mu$ A at nominal input voltage.

**24 V DC systems**

The input voltage to the DC/DC converter is SELV (Safety Extra Low Voltage) and the output remains SELV under normal and abnormal operating conditions.

**48 and 60 V DC systems**

If the input voltage to the DC/DC converter is 75 Vdc or less, then the output remains SELV (Safety Extra Low Voltage) under normal and abnormal operating conditions.

Single fault testing in the input power supply circuit should be performed with the DC/DC converter connected to demonstrate that the input voltage does not exceed 75 Vdc.

If the input power source circuit is a DC power system, the source may be treated as a TNV2 circuit and testing has demonstrated compliance with SELV limits and isolation requirements equivalent to Basic Insulation in accordance with IEC/EN/UL60950.

**Non-isolated DC/DC regulators**

The input voltage to the DC/DC regulator is SELV (Safety Extra Low Voltage) and the output remains SELV under normal and abnormal operating conditions.

**PKM4000B series Intermediate Bus Converters**  
 Input 36-75 V, Output up to 33 A / 380 W

EN/LZT 146 305 R6B June 2010

© Ericsson AB

**Absolute Maximum Ratings**

Characteristics		min	typ	max	Unit
T <sub>ref</sub>	Operating Temperature (see Thermal Consideration section)	Open frame		+125	°C
		Base plate option		+95	
T <sub>s</sub>	Storage temperature	-55		+125	°C
V <sub>I</sub>	Input voltage	-0.5		+80	V
V <sub>iso</sub>	Isolation voltage (input to output test voltage)			1500	Vdc
V <sub>tr</sub>	Input voltage transient (t <sub>p</sub> 100 ms)			100	V
V <sub>RC</sub>	Remote Control pin voltage (see Operating Information section)	Positive logic option		15	V
		Negative logic option	-0.5	15	

Stress in excess of Absolute Maximum Ratings may cause permanent damage. Absolute Maximum Ratings, sometimes referred to as no destruction limits, are normally tested with one parameter at a time exceeding the limits of Output data or Electrical Characteristics. If exposed to stress above these limits, function and performance may degrade in an unspecified manner.

**Fundamental Circuit Diagram**

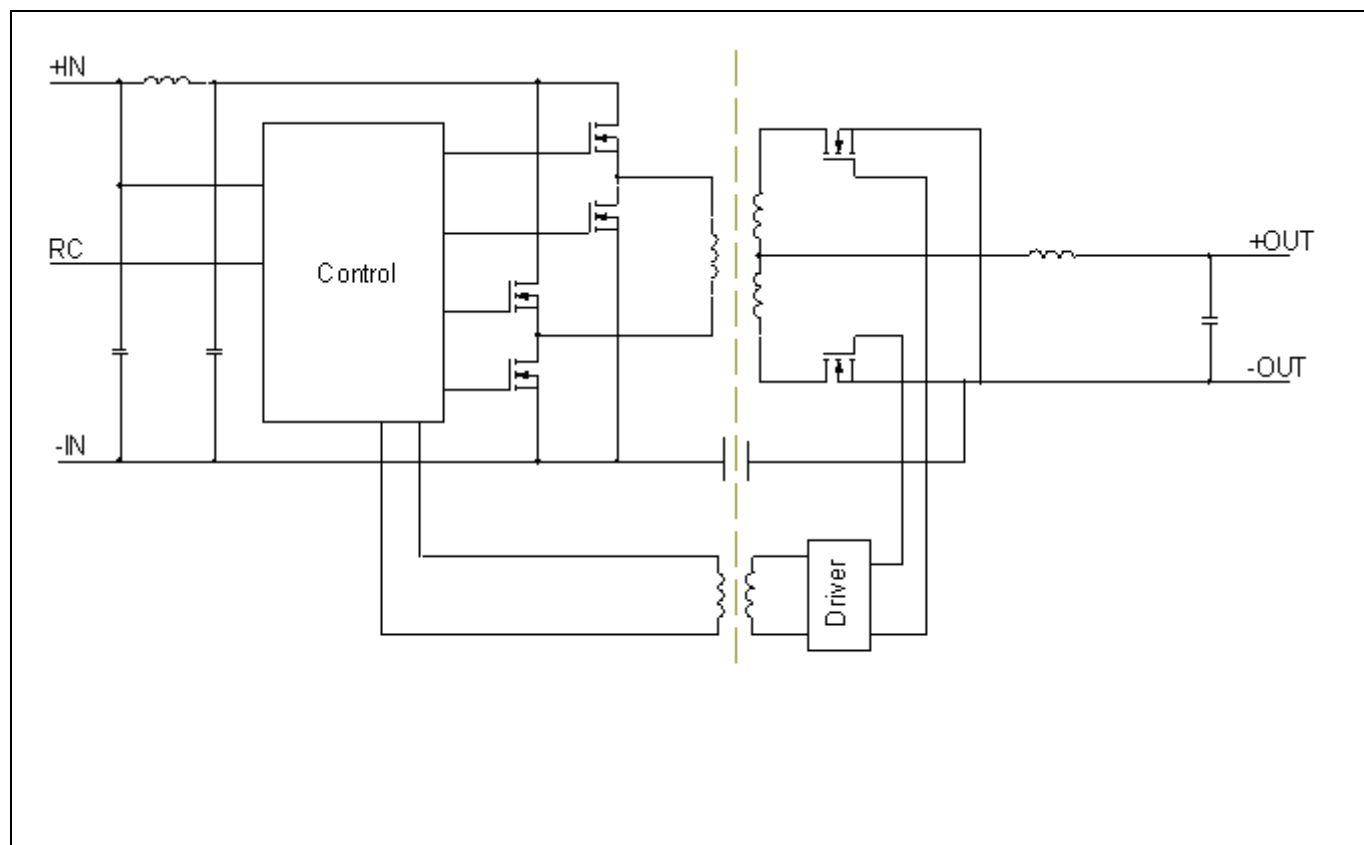

**PKM4000B series Intermediate Bus Converters**  
 Input 36-75 V, Output up to 33 A / 380 W

EN/LZT 146 305 R6B June 2010

© Ericsson AB

**12 V/25 A Electrical Specification**
**PKM 4204B PI**
 $T_{ref} = -40$  to  $+90^{\circ}$  C for open frame and  $-40$  to  $+60^{\circ}$ C for base plate option,  $V_I = 36$  to  $75$  V,  $I_O = 0$  to  $25$  A unless otherwise specified under Conditions.

 Typical values given at:  $T_{ref} = +25^{\circ}$ C,  $V_I = 53$  V, max  $I_O$ , unless otherwise specified under Conditions.

Characteristics		Conditions	Min	typ	max	Unit
$V_I$	Input voltage range		36		75	V
$V_{loff}$	Turn-off input voltage	Decreasing input voltage	32	33	34	V
$V_{lon}$	Turn-on input voltage	Increasing input voltage	34	35.2	36	V
$C_I$	Internal input capacitance			17.6		$\mu$ F
$P_O$	Output power	$V_I = 75$ V	0		290	W
		$V_I = 53$ V	0		286	W
		$V_I = 36$ V	0		283	W
$\eta$	Efficiency	50 % of max $I_O$		96.2		%
		max $I_O$		95.8		
		50 % of max $I_O$ , $V_I = 48$ V		96.4		
		max $I_O$ , $V_I = 48$ V		95.9		
$P_d$	Power Dissipation	max $I_O$		12.4		W
$P_{ii}$	Input idling power	$I_O = 0$ A, $V_I = 53$ V		3		W
$P_{RC}$	Input standby power	$V_I = 53$ V (turned off with RC)		0.1		W
$f_s$	Switching frequency		100	125	150	kHz

$V_{oi}$	Output voltage initial setting and accuracy	$T_{ref} = +25^{\circ}$ C, $V_I = 53$ V, $I_O = 0$ A	11.85	11.9	11.95	V
$V_O$	Output voltage tolerance band	0 to 100 % of max $I_O$	11.0		12.5	V
	Idling voltage	$I_O = 0$ A	11.5		12.5	V
	Line regulation	max $I_O$ , from min $V_I$ to max $V_I$		0.2		V
	Load regulation	$V_I = 53$ V, from min $I_O$ to max $I_O$		0.4		V
$V_{tr}$	Load transient voltage deviation	$V_I = 53$ V, Load step 25-75-25 % of max $I_O$ , $di/dt = 5$ A/ $\mu$ s		$\pm 0.8$		V
$t_{tr}$	Load transient recovery time	see Note 1		0.1		ms
$t_r$	Ramp-up time (from 10-90 % of $V_{oi}$ )	max $I_O$	3	7	15	ms
$t_s$	Start-up time (from $V_I$ connection to 90 % of $V_{oi}$ )		4	12	25	ms
$t_f$	$V_I$ shut-down fall time (from $V_I$ off to 10 % of $V_O$ )	max $I_O$		0.1		ms
		$I_O = 0$ A		2.4		s
$t_{RC}$	RC start-up time	max $I_O$		10		ms
	RC shut-down fall time (from RC off to 10 % of $V_O$ )	max $I_O$		6		ms
		$I_O = 0$ A		2.4		s
$I_O$	Output current		0		25	A
$I_{lim}$	Current limit threshold	$T_{ref} < \max T_{ref}$		36		A
$I_{sc}$	Short circuit current	$T_{ref} = 25^{\circ}$ C, see Note 2		42		A
$V_{Oac}$	Output ripple & noise	See ripple & noise section, max $I_O$		200		mVp-p
OVP	Input over voltage protection			83		V
	Output over voltage protection			13.5		

 Note 1: Output filter 2 x 220  $\mu$ F, 100 m $\Omega$ , tantalum + 33  $\mu$ F, ceramic

Note 2: See Operating Information section

**PKM4000B series** Intermediate Bus Converters  
 Input 36-75 V, Output up to 33 A / 380 W

EN/LZT 146 305 R6B June 2010

© Ericsson AB

**12 V/25 A Typical Characteristics**

**PKM 4204B PI**

**Efficiency**

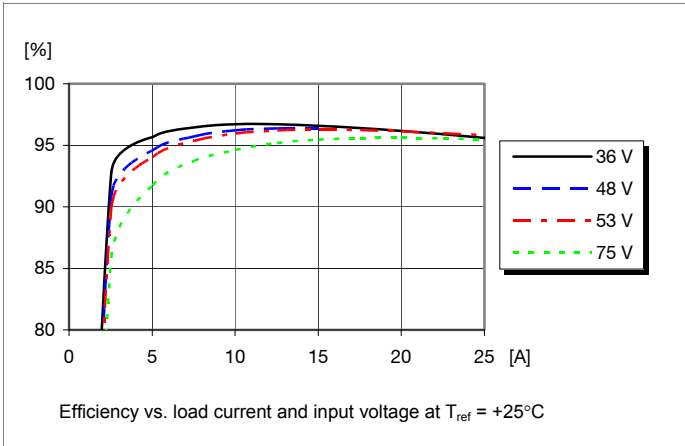

**Power Dissipation**

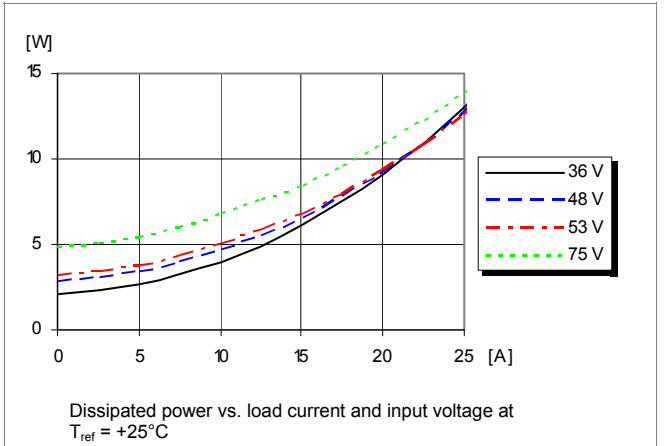

**Output Characteristics**

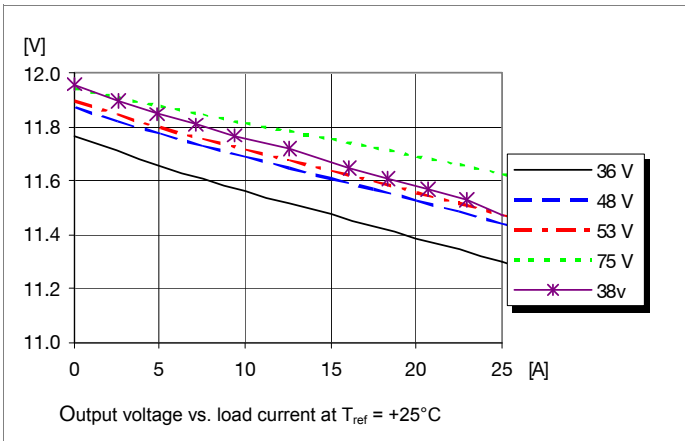

**Current Limit Characteristics**

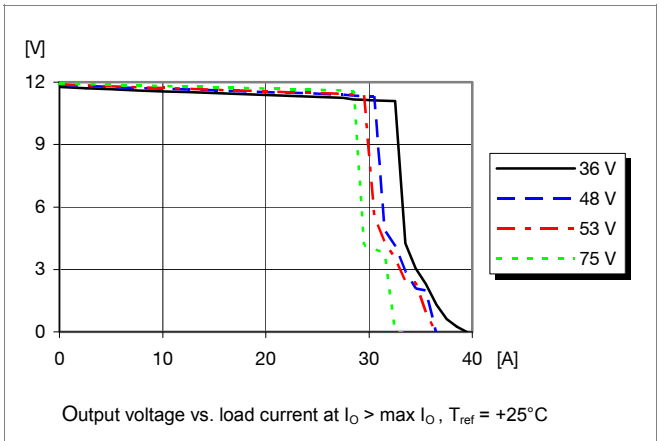

**PKM4000B series Intermediate Bus Converters**  
 Input 36-75 V, Output up to 33 A / 380 W

EN/LZT 146 305 R6B June 2010

© Ericsson AB

**12 V/25 A Typical Characteristics**

**PKM 4204B PI**

**Output Current Derating, open frame**

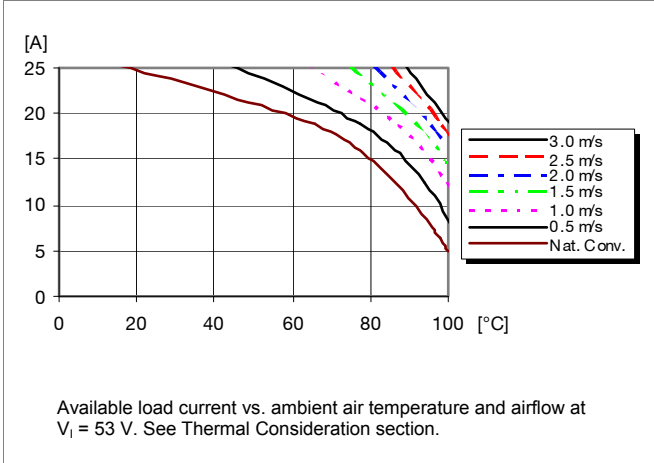

**Thermal Resistance, open frame**

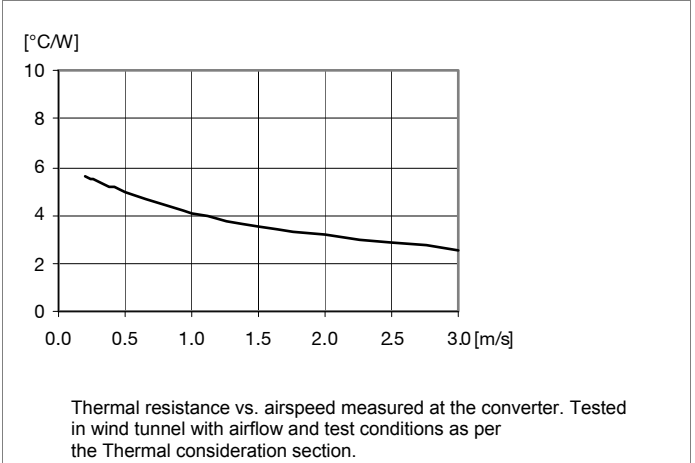

**Output Current Derating, base plate option**

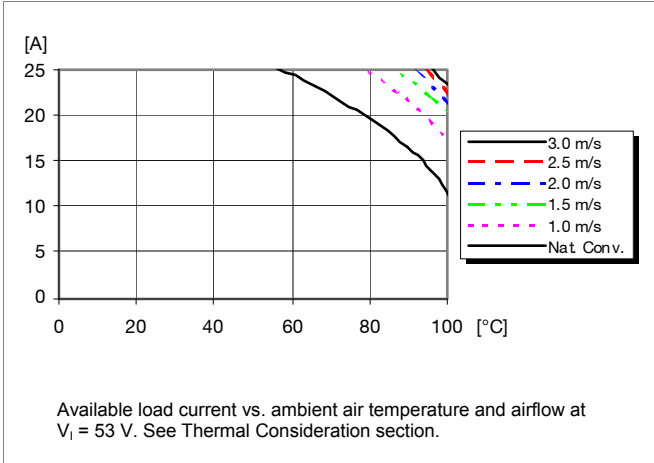

**Thermal Resistance, base plate option**

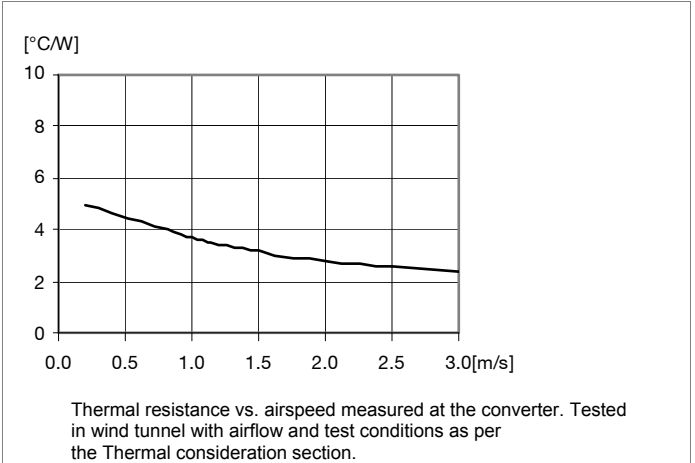

**Output Current Derating, base plate option with heat sink**

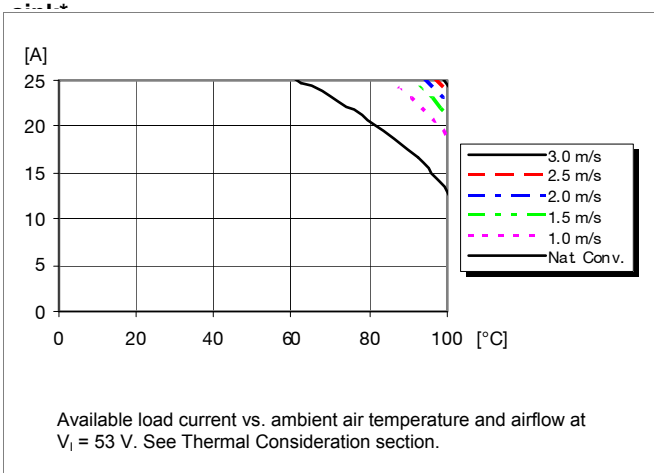

**Thermal Resistance, base plate option with heat sink\***

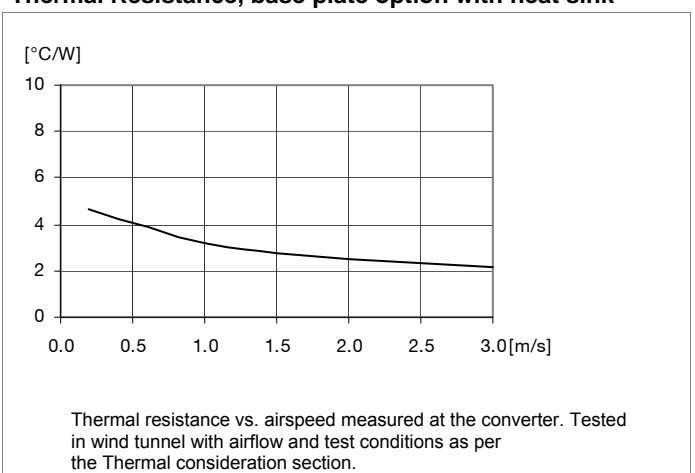

\* Heat sink: finned aluminium, height: 0.23"; Thermal pad: thermal conductivity: 6W/mK, thickness: 0.25mm; Mounting: two M3 screws, torque: 0.44Nm  
 NOTE: the product is not mechanically tested with heat sink

**PKM4000B series** Intermediate Bus Converters  
 Input 36-75 V, Output up to 33 A / 380 W

EN/LZT 146 305 R6B June 2010

© Ericsson AB

**12 V/25 A Typical Characteristics**

**PKM 4204B PI**

**Start-up**

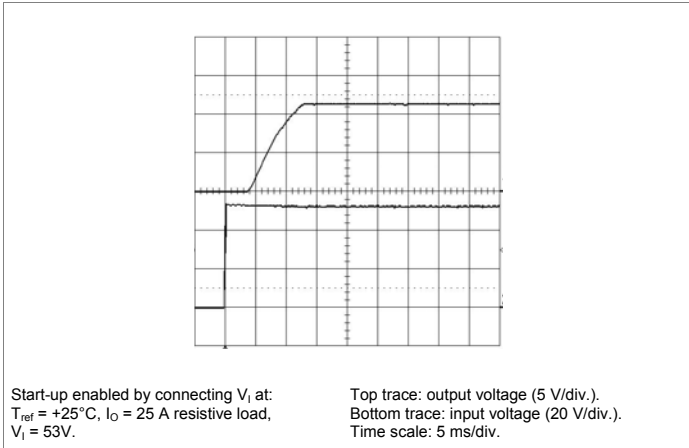

**Shut-down**

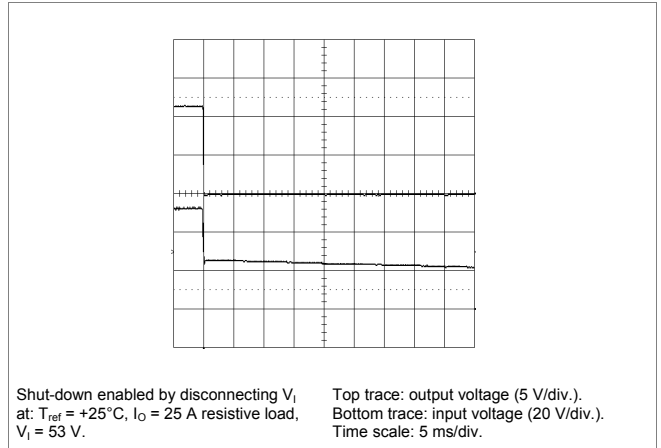

**Output Ripple & Noise**

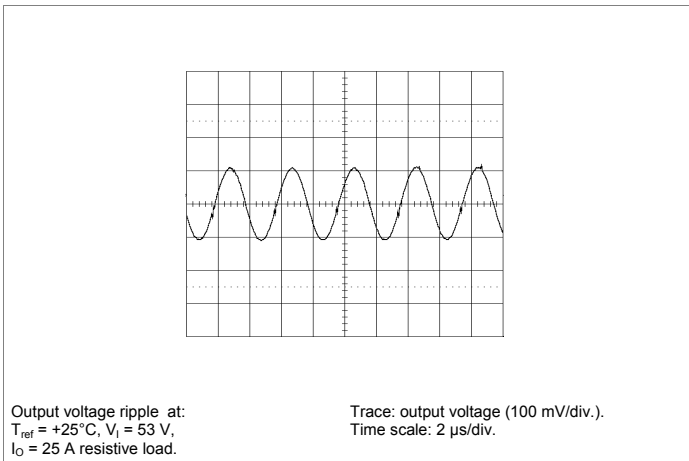

**Output Load Transient Response**

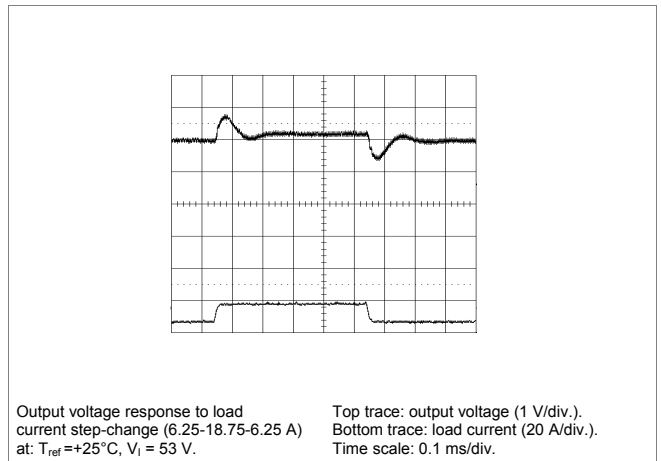



**PKM4000B series Intermediate Bus Converters**  
 Input 36-75 V, Output up to 33 A / 380 W

EN/LZT 146 305 R6B June 2010

© Ericsson AB

**12 V/33 A Electrical Specification**
**PKM 4304B PI**
 $T_{ref} = -40$  to  $+90^{\circ}\text{C}$  for open frame and  $-40$  to  $+60^{\circ}\text{C}$  for base plate option,  $V_i = 36$  to  $75$  V,  $I_o = 0$  to  $33$  A unless otherwise specified under Conditions.

 Typical values given at:  $T_{ref} = +25^{\circ}\text{C}$ ,  $V_i = 53$  V, max  $I_o$ , unless otherwise specified under Conditions.

Characteristics		Conditions	min	typ	max	Unit
$V_i$	Input voltage range		36		75	V
$V_{loff}$	Turn-off input voltage	Decreasing input voltage	32	33	34	V
$V_{lon}$	Turn-on input voltage	Increasing input voltage	34	35.2	36	V
$C_i$	Internal input capacitance			17.6		$\mu\text{F}$
$P_o$	Output power	$V_i = 75$ V	0		380	W
		$V_i = 53$ V	0		377	W
		$V_i = 36$ V	0		371	W
$\eta$	Efficiency	50 % of max $I_o$		96.3		%
		max $I_o$		95.2		
		50 % of max $I_o$ , $V_i = 48$ V		96.4		
		max $I_o$ , $V_i = 48$ V		95.3		
$P_d$	Power Dissipation	max $I_o$		18	34	W
$P_{ii}$	Input idling power	$I_o = 0$ A, $V_i = 53$ V		4		W
$P_{RC}$	Input standby power	$V_i = 53$ V (turned off with RC)		0.1		W
$f_s$	Switching frequency		100	125	150	kHz

$V_{oi}$	Output voltage initial setting and accuracy	$T_{ref} = +25^{\circ}\text{C}$ , $V_i = 53$ V, $I_o = 0$ A	11.85	11.9	11.95	V
$V_o$	Output voltage tolerance band	0 to 100 % of max $I_o$	10.8		12.5	V
	Idling voltage	$I_o = 0$ A	11.5		12.5	V
	Line regulation	max $I_o$ , from min $V_i$ to max $V_i$		0.2	0.6	V
	Load regulation	$V_i = 53$ V, from min $I_o$ to max $I_o$		0.5	0.9	V
$V_{tr}$	Load transient voltage deviation	$V_i = 53$ V, Load step 25-75-25 % of max $I_o$ , $di/dt = 5$ A/ $\mu\text{s}$ see Note 1		$\pm 1$		V
$t_{tr}$	Load transient recovery time			0.1		ms
$t_r$	Ramp-up time (from 10-90 % of $V_{oi}$ )	max $I_o$	3	7	15	ms
$t_s$	Start-up time (from $V_i$ connection to 90 % of $V_{oi}$ )		4	12	25	ms
$t_f$	$V_i$ shut-down fall time (from $V_i$ off to 10 % of $V_o$ )	max $I_o$		0.1		ms
		$I_o = 0$ A		2.4		s
$t_{RC}$	RC start-up time	max $I_o$		10		ms
	RC shut-down fall time (from RC off to 10 % of $V_o$ )	max $I_o$		6		ms
		$I_o = 0$ A		2.4		s
$I_o$	Output current		0		33	A
$I_{lim}$	Current limit threshold	$T_{ref} < \max T_{ref}$		41		A
$I_{sc}$	Short circuit current	$T_{ref} = 25^{\circ}\text{C}$ , see Note 2		47		A
$V_{Oac}$	Output ripple & noise	See ripple & noise section, max $I_o$		200		mVp-p
OVP	Input over voltage protection			83		V
	Output over voltage protection			13.5		

 Note 1: Output filter 2 x 220  $\mu\text{F}$ , 100 m $\Omega$ , tantalum + 33  $\mu\text{F}$ , ceramic

Note 2: See Operating Information section

**PKM4000B series** Intermediate Bus Converters  
 Input 36-75 V, Output up to 33 A / 380 W

EN/LZT 146 305 R6B June 2010

© Ericsson AB

**12 V/33 A Typical Characteristics**

**PKM 4304B PI**

**Efficiency**

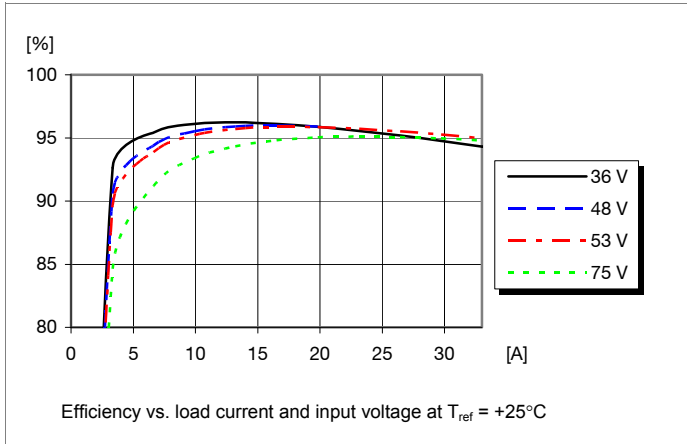

**Power Dissipation**

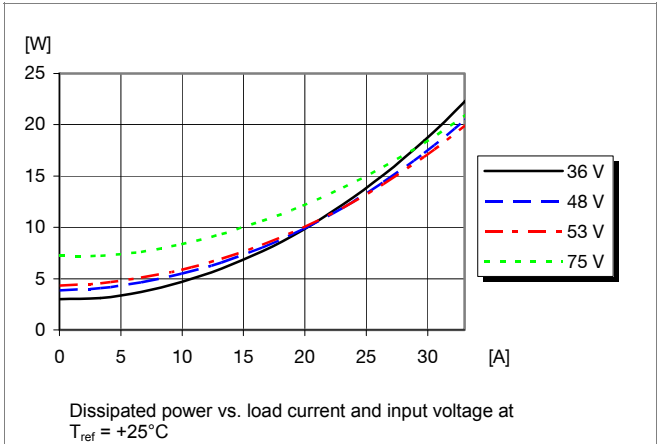

**Output Characteristics**

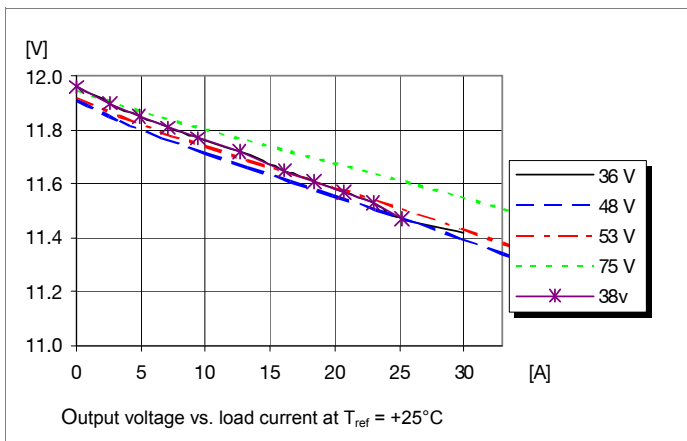

**Current Limit Characteristics**

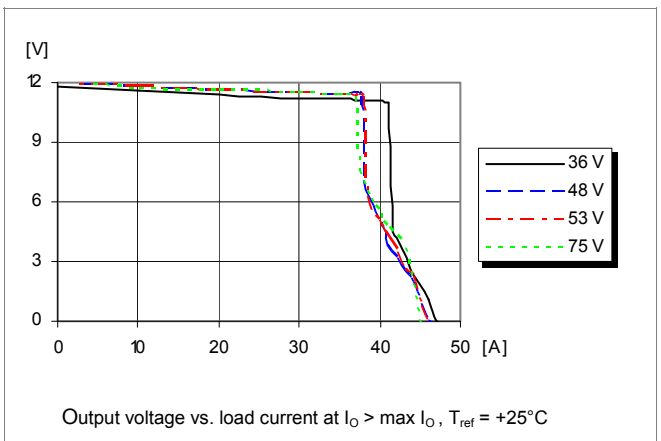

**PKM4000B series Intermediate Bus Converters**  
 Input 36-75 V, Output up to 33 A / 380 W

EN/LZT 146 305 R6B June 2010

© Ericsson AB

**12 V/33 A Typical Characteristics**

**PKM 4304B PI**

**Output Current Derating, open frame**

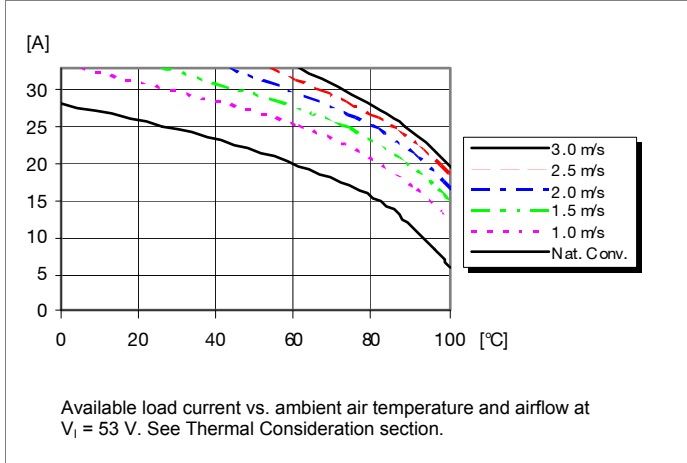

**Thermal Resistance, open frame**

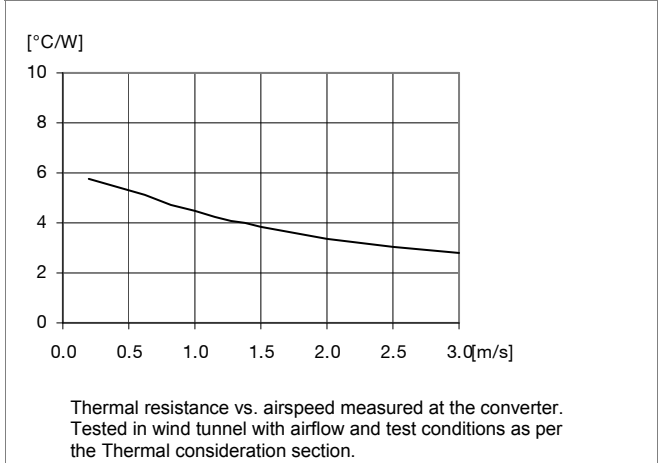

**Output Current Derating, base plate option**

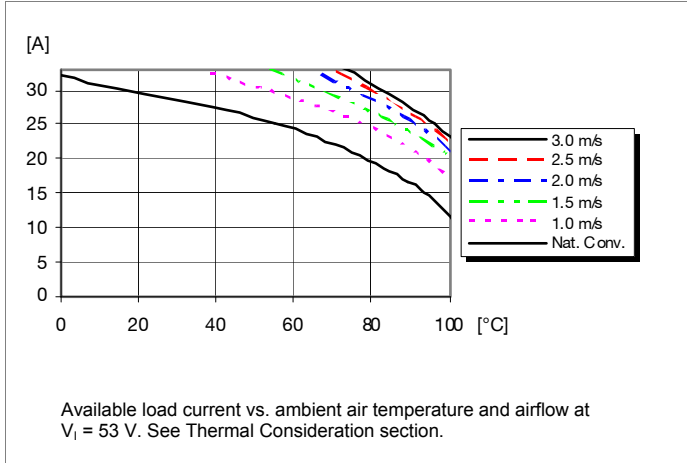

**Thermal Resistance, base plate option**

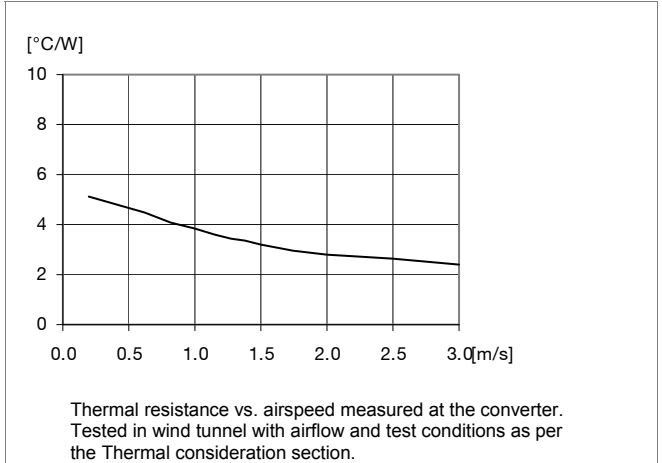

**Output Current Derating, base plate option with heat sink\***

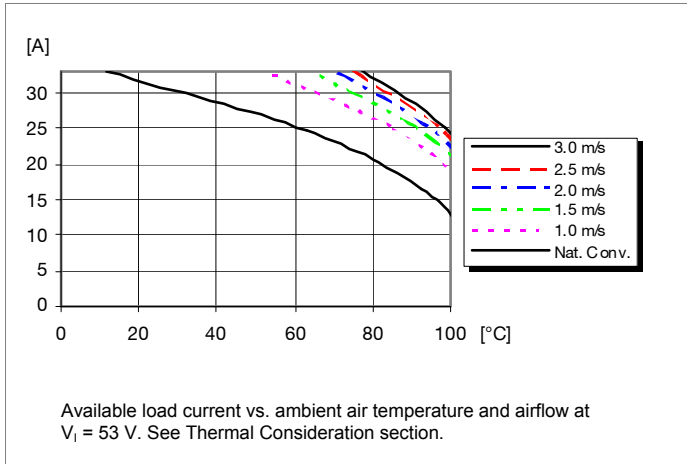

**Thermal Resistance, base plate option with heat sink\***

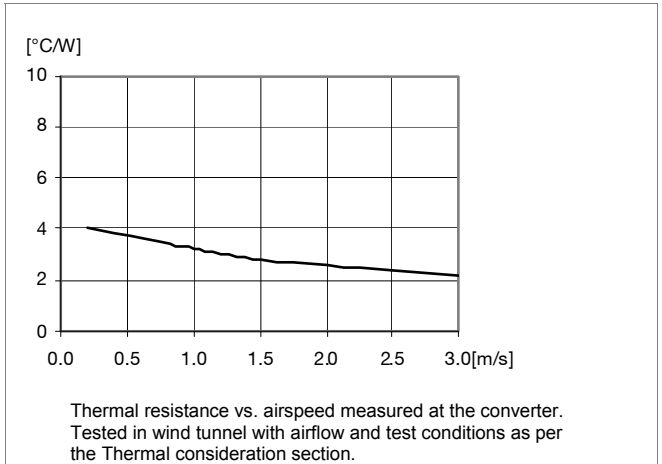

\*<sup>1)</sup> Heat sink: finned aluminium, height: 0.23"; Thermal pad: thermal conductivity: 6W/mK, thickness: 0.25mm; Mounting: two M3 screws, torque: 0.44Nm  
 NOTE: the product is not mechanically tested with heat sink

**PKM4000B series** Intermediate Bus Converters  
 Input 36-75 V, Output up to 33 A / 380 W

EN/LZT 146 305 R6B June 2010

© Ericsson AB

**12 V/33 A Typical Characteristics**

**PKM 4304B PI**

**Start-up**

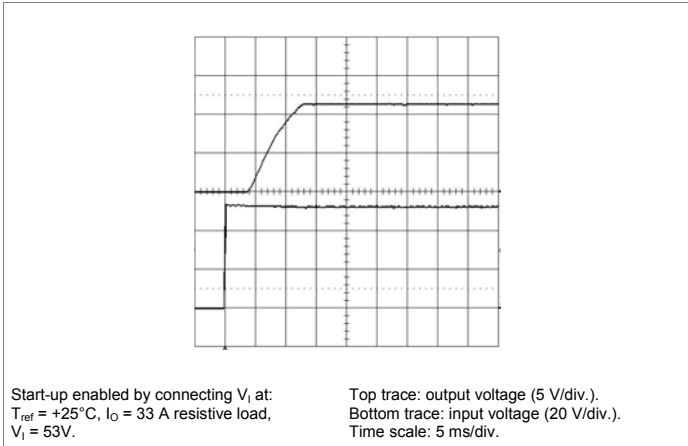

**Shut-down**

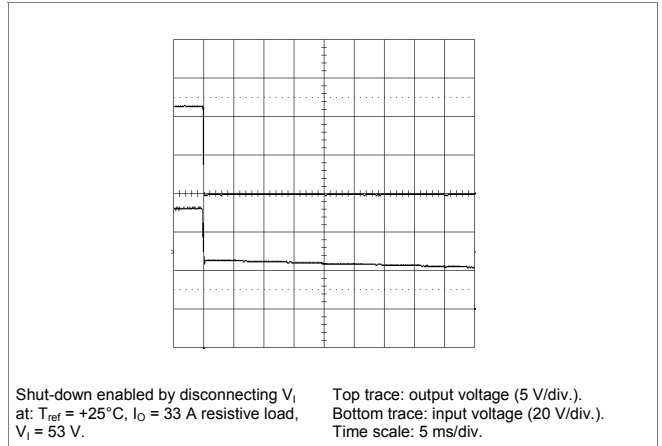

**Output Ripple & Noise**

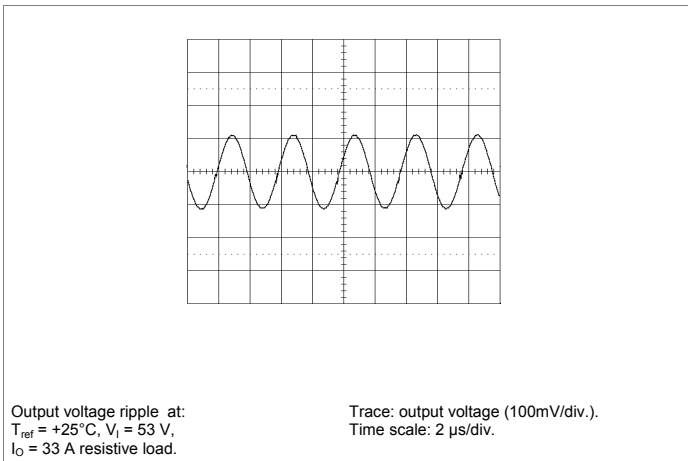

**Output Load Transient Response**

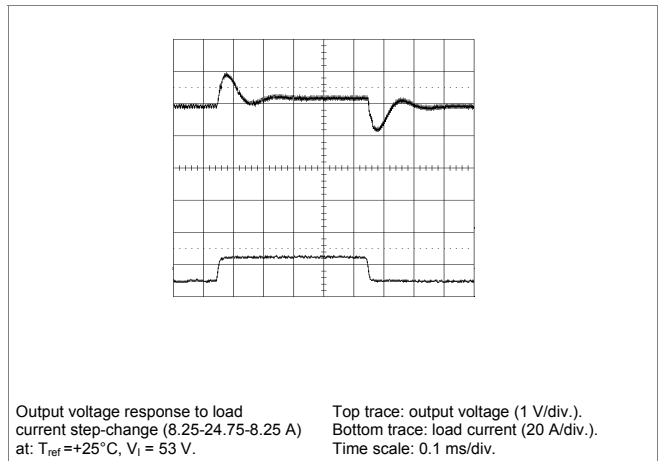

**PKM4000B series Intermediate Bus Converters**  
 Input 36-75 V, Output up to 33 A / 380 W

EN/LZT 146 305 R6B June 2010

© Ericsson AB

**EMC Specification**

Conducted EMI measured according to EN55022, CISPR 22 and FCC part 15J (see test set-up). See Design note 009 for detailed information.  
 The fundamental switching frequency is 125 kHz for PKM 4304B PI @  $V_I = 53$  V, max  $I_O$ .

**Conducted EMI Input terminal value (typ)**

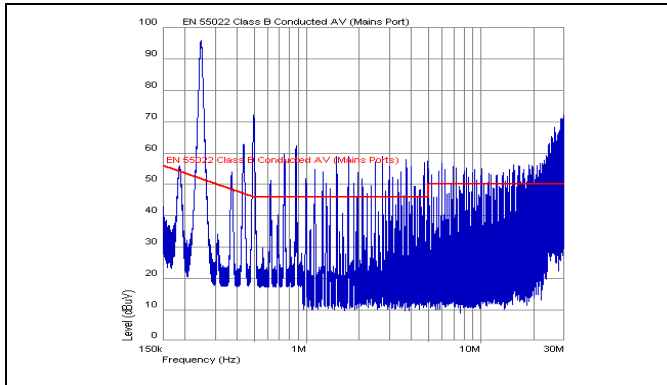

EMI without filter

**External filter (class B)**

Required external input filter in order to meet class B in EN 55022, CISPR 22 and FCC part 15J.

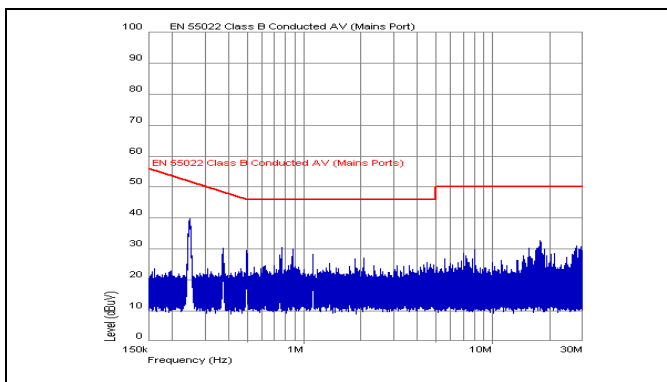
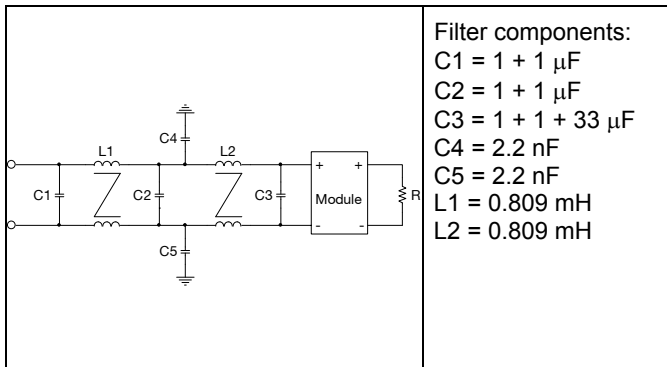

EMI with filter

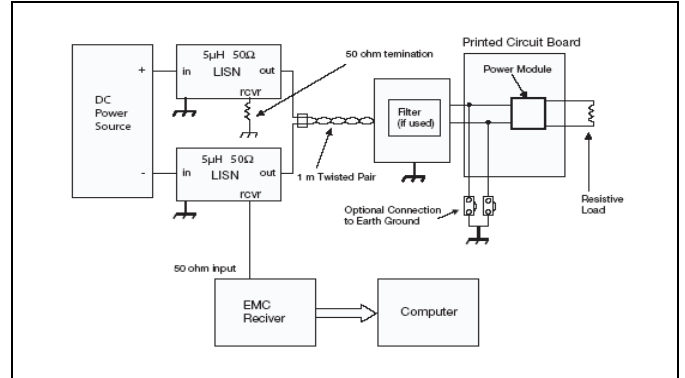

Test set-up

**Layout recommendation**

The radiated EMI performance of the DC/DC converter will depend on the PCB layout and ground layer design. It is also important to consider the stand-off of the DC/DC converter. If a ground layer is used, it should be connected to the output of the DC/DC converter and the equipment ground or chassis.

A ground layer will increase the stray capacitance in the PCB and improve the high frequency EMC performance.

**Output ripple and noise**

Output ripple and noise measured according to figure below. See Design Note 022 for detailed information.

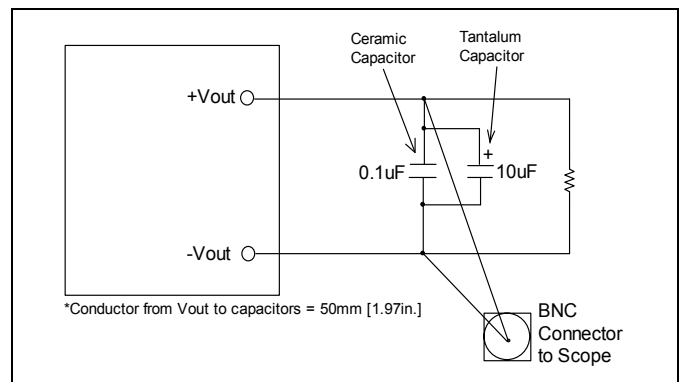

Output ripple and noise test setup

**PKM4000B series Intermediate Bus Converters**  
 Input 36-75 V, Output up to 33 A / 380 W

EN/LZT 146 305 R6B June 2010

© Ericsson AB

**Operating information**

**Input Voltage**

The input voltage range 36 to 75 Vdc meets the requirements of the European Telecom Standard ETS 300 132-2 for normal input voltage range in -48 and -60 Vdc systems, -40.5 to -57.0 V and -50.0 to -72 V respectively. At input voltages exceeding 75 V, the power loss will be higher than at normal input voltage and  $T_{ref}$  must be limited to absolute max 115°C. The absolute maximum continuous input voltage is 80 Vdc.

**Turn-off Input Voltage**

The DC/DC converters monitor the input voltage and will turn on and turn off at predetermined levels. The minimum hysteresis between turn on and turn off input voltage is 1 V.

**Remote Control (RC)**

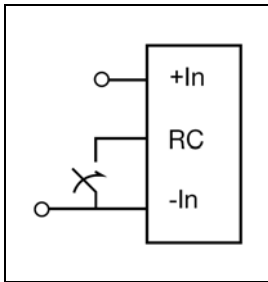

The products are fitted with a remote control function referenced to the primary negative input connection (- In), and positive logic options available. The RC function allows the DC/DC converter to be turned on/off by an external device like a semiconductor or mechanical switch. The RC pin has an internal pull up resistor to + In.

The maximum required sink current is 0.2 mA. When the RC pin is left open, the voltage generated on the RC pin is max 10 V. The second option is "positive logic" remote control, which can be ordered by adding the suffix "P" to the end of the part number. The DC/DC converter will turn on when the RC pin is left open. Turn off is achieved by connecting the RC pin to the - In. To ensure safe turn off the voltage difference between RC pin and the - In pin shall be less than 1V. The DC/DC converter will restart automatically when this connection is opened.

**Input and Output Impedance**

The impedance of both the input source and the load will interact with the impedance of the DC/DC converter. It is important that the input source has low characteristic impedance. The performance in some applications can be enhanced by addition of external capacitance as described under External Decoupling Capacitors. If the input voltage source contains significant inductance, the addition of a 330 µF capacitor across the input of the DC/DC converter will ensure stable operation.

**External Decoupling Capacitors**

When powering loads with significant dynamic current requirements, the voltage regulation at the point of load can be improved by addition of decoupling capacitors at the load. The most effective technique is to locate low ESR ceramic and electrolytic capacitors as close to the load as possible, using

several parallel capacitors to lower the effective ESR. The ceramic capacitors will handle high-frequency dynamic load changes while the electrolytic capacitors are used to handle low frequency dynamic load changes. Ceramic capacitors will also reduce any high frequency noise at the load. It is equally important to use low resistance and low inductance PWB layouts and cabling.

For semi-regulated or fixed turns ratio IBC (intermediate bus converters), there is no limit on the value of external output capacitance, but there are practical performance considerations that need to be made when using very large capacitor values such as ramp-up time of the DC/DC converter output voltage during start-up or turn-off discharge considerations. If there are any questions associated with a specific application configuration, please contact your local Ericsson representative for support.

**Parallel Operation**

The PKM 4000B Series DC/DC converters can be connected in parallel with a common input. Paralleling is accomplished by connecting the output voltage pins and input pins directly. No external components are necessary. Up to 90% of max output current can be used from each module. Layout considerations should be made to avoid unbalanced current sharing. For more details on paralleling, please consult your local Ericsson Power Modules representative.

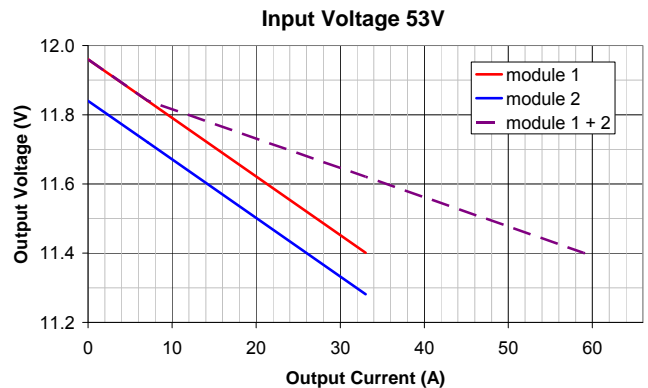

**PKM4000B series Intermediate Bus Converters**  
Input 36-75 V, Output up to 33 A / 380 W

EN/LZT 146 305 R6B June 2010

© Ericsson AB

**Over Temperature Protection (OTP)**

The DC/DC converters are protected from thermal overload by an internal over temperature shutdown circuit.

When  $T_{ref}$  as defined in thermal consideration section exceeds 125°C the DC/DC converter will shut down. The DC/DC converter will make continuous attempts to start up (non latching mode) We provide an optional variant of the product with a latching OTP. Add suffix "LP" to the standard product code to order the latching version. The latching OTP version has a latching OVP as well.

If the OTP/OVP is latched the module can be put in operation either by switching OFF and ON the input voltage or drive OFF and ON the RC (Remote Control) pin.

**Over Voltage Protection (OVP)**

The DC/DC converters have output over voltage protection that will shut down the DC/DC converter in over voltage conditions. The DC/DC converter will make continuous attempts to start up (non-latching mode) and resume normal operation automatically after removal of the over voltage condition.

Add suffix "LP" to the standard product code to order the latching version. The latching OVP version has a latching OTP as well.

If the OTP/OVP is latched the module can be put in operation either by switching OFF and ON the input voltage or drive OFF and ON the RC (Remote Control) pin.

**Over Current Protection (OCP)**

The DC/DC converters include current limiting circuitry for protection at continuous overload.

The output voltage will decrease towards zero when the output current exceeds max output current (max  $I_o$ ).

Under output short circuit, when the output current is in excess of max output current (max  $I_o$ ), the DC/DC Converter will enter a hiccup mode protection. The DC/DC converter will resume normal operation after removal of the overload or short circuit.

**PKM4000B series Intermediate Bus Converters**  
 Input 36-75 V, Output up to 33 A / 380 W

EN/LZT 146 305 R6B June 2010

© Ericsson AB

**Thermal Consideration**

**General**

The product is designed to operate in various thermal environments and sufficient cooling must be provided to ensure reliable operation. Cooling is achieved mainly by conduction, from the pins to the host board, and convection. The size and copper thickness of the host board will have impact on the Conduction cooling. Convection cooling is dependant on the airflow across the DC/DC converter. Increased airflow enhances the cooling of the DC/DC converter.

The Output Current Derating graph found in the Output section for each model provides the available output current vs. ambient air temperature and air velocity at  $V_{in} = 53 V$ .

The DC/DC converter is tested on a 254 x 254 mm, 35  $\mu m$  (1 oz), 16-layer test board mounted vertically in a wind tunnel with a cross-section of 305 x 305 mm.

Proper cooling of the DC/DC converter can be verified by measuring the temperature at reference point. The temperature at these positions should not exceed the max values provided in the table below.

Position	Device	Designation	max value
Reference	PCB	-	125°C

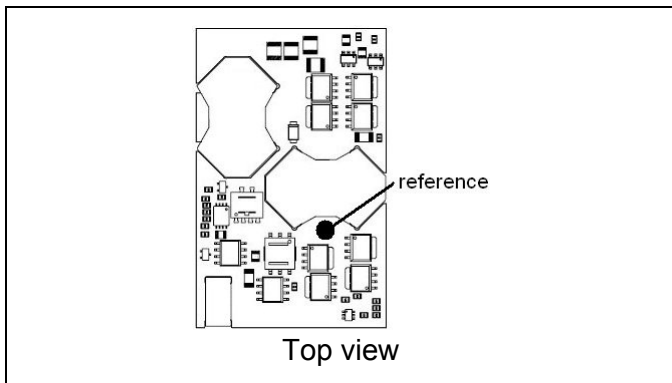

**Definition of reference temperature ( $T_{ref}$ )**

The reference temperature is used to monitor the temperature limits of the product. Temperatures above maximum  $T_{ref}$  are not allowed and may cause degradation or permanent damage to the product.  $T_{ref}$  is also used to define the temperature range for normal operating conditions.  $T_{ref}$  is defined by the design and used to guarantee safety margins, proper operation and reliability of the module.

**Ambient Temperature Calculation**

By using the thermal resistance the estimated maximum allowed ambient temperature can be calculated.

1. The power loss is calculated by using the formula  $((1/\eta) - 1) \times \text{output power} = \text{power losses (Pd)}$ .  
 $\eta$  = efficiency of converter. E.g 96 % = 0.96
2. Find the thermal resistance ( $R_{th}$ ) in the Thermal Resistance graph found in the Output section for each model. Calculate the temperature increase ( $\Delta T$ ).  
 $T = R_{th} \times P_d$
3. Max allowed ambient temperature is:  
 $T_a = \text{Max } T_{ref} - \Delta T$ .

E.g. PKM4204B PI at 53Vin 20Aout 1.5 m/s

1.  $((1/0.96) - 1) \times 240W = 10 W$
2.  $10 W \times 3.5^\circ C = 35^\circ C$
3.  $125^\circ C - 35^\circ C = \text{max ambient temperature is } 90^\circ C$

The actual temperature will be dependent on several factors such as the PCB size, number of layers and direction of airflow.



**PKM4000B series** Intermediate Bus Converters  
 Input 36-75 V, Output up to 33 A / 380 W

EN/LZT 146 305 R6B June 2010

© Ericsson AB

**Connections**

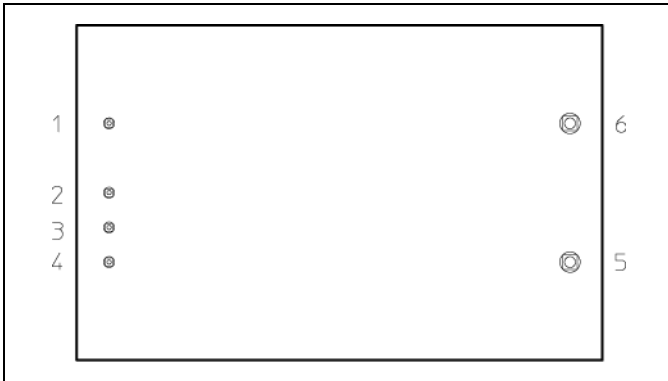

Pin	Designation	Function
1	+In	Positive input
2	RC	Remote control
3	Case	Case to GND (optional)
4	-In	Negative input
5	-Out	Negative output
6	+Out	Positive output

**PKM4000B series Intermediate Bus Converters**  
 Input 36-75 V, Output up to 33 A / 380 W

EN/LZT 146 305 R6B June 2010

© Ericsson AB

**Mechanical Information – Through hole mount version**

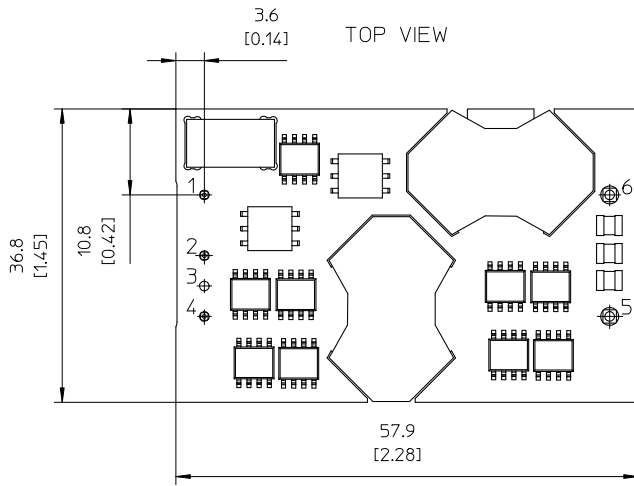
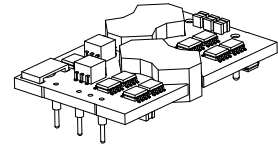
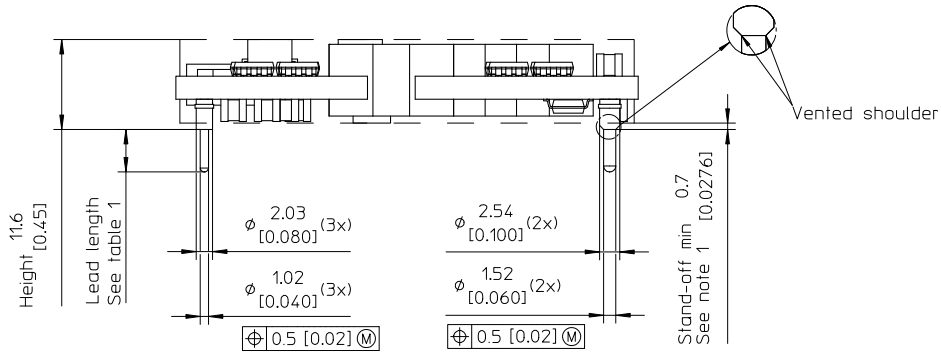

RECOMMENDED FOOTPRINT - TOP VIEW

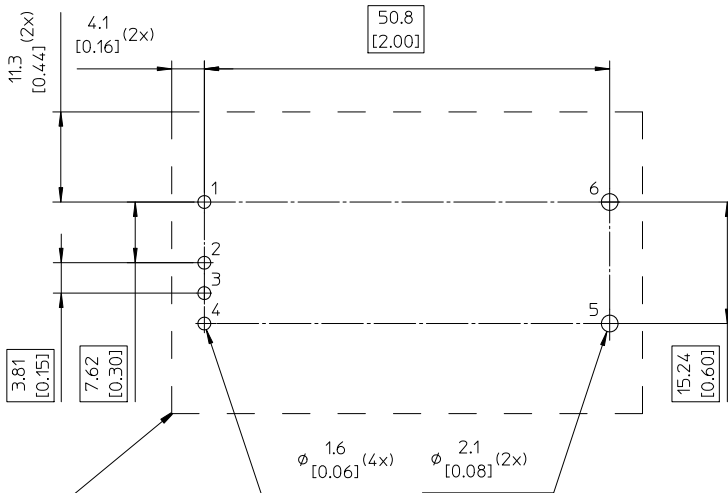

Recommended keep away area for user components.  
 The standoff in combination with insulating material ensures that requirements as per IEC/EN/UL60950 are met and 1500 V isolation maintained even if open vias or traces are present under the DC/DC-converter.

Table 1

Pin option	Lead Length
Standard	5.33 [0.210]
LA	3.69 [0.145]
LB	4.57 [0.180]
LC	2.79 [0.110]

Pins:  
 Material: Copper alloy  
 Plating: 0.1 μm Gold over 2 μm Nickel  
 Pin 3 is optional and only used for base plate connection

- Notes
- 1- Stand off to none conductive components min 0.7 [0.027]
  - Stand off to conductive components min 0.95 [0.037]
  - For details see safety section page 3.

Weight: Typical 48 g  
 All dimensions in mm [inch].  
 Tolerances unless specified  
 x.x mm ±0.50 [0.02], x.xx mm ±0.25 [0.01]  
 (not applied on footprint or typical values)



**PKM4000B series Intermediate Bus Converters**  
 Input 36-75 V, Output up to 33 A / 380 W

EN/LZT 146 305 R6B June 2010

© Ericsson AB

**Mechanical Information- Base plate**

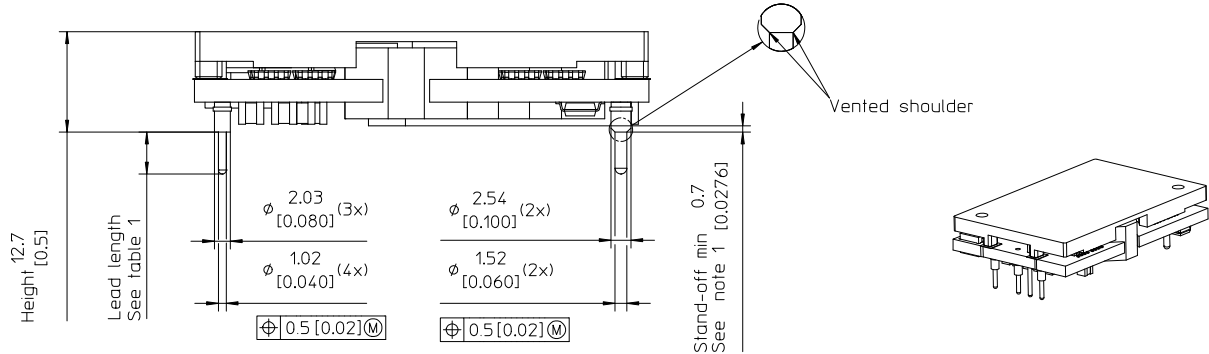

TOP VIEW

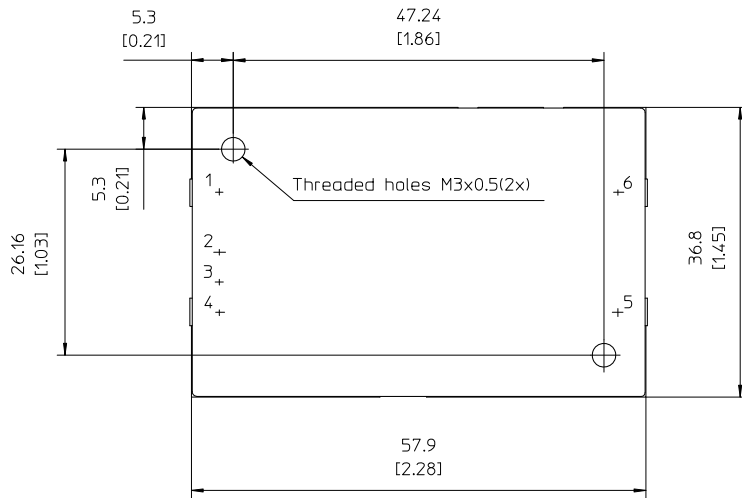

RECOMMENDED FOOTPRINT - TOP VIEW

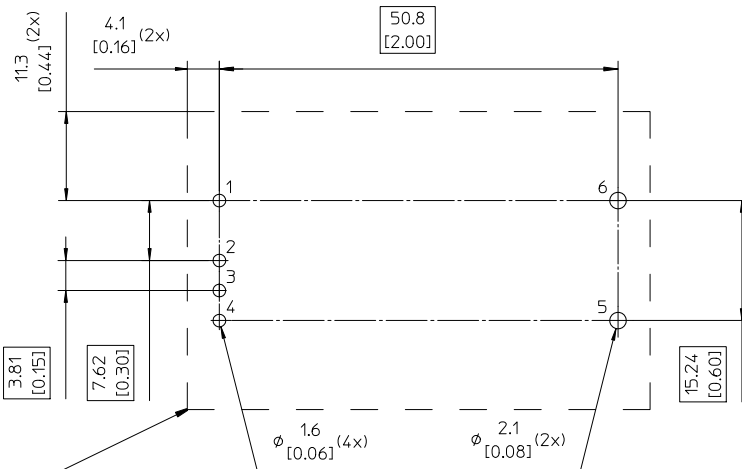

Recommended keep away area for user components.  
 The standoff in combination with insulating material ensures that requirements as per IEC/EN/UL60950 are met and 1500 V isolation maintained even if open vias or traces are present under the DC/DC-converter.

Table 1

Pin option	Lead Length
Standard	5.33 [0.210]
LA	3.69 [0.145]
LB	4.57 [0.180]
LC	2.79 [0.110]

Case:

Material: Aluminium

- For screw attachment apply mounting torque of max 0.44 Nm [3.9 lbf in].
- M3 screws must not protrude more than 2.7 [0.106] in to the base plate.

Pins:

Material: Copper alloy

Plating: 0.1 µm Gold over 2 µm Nickel

Pin 3 is optional and only used for base plate connection

Notes

- 1- Stand off to none conductive components min 0.7 [0.027]
- Stand off to conductive components min 0.95 [0.037]
- For details see safety section page 3.

Weight: Typical 67 g

All dimensions in mm [inch].

Tolerances unless specified

x.xx mm ±0.50 [0.02], x.xx mm ±0.25 [0.01]

(not applied on footprint or typical values)



**PKM4000B series Intermediate Bus Converters**  
 Input 36-75 V, Output up to 33 A / 380 W

EN/LZT 146 305 R6B June 2010

© Ericsson AB

**Mechanical information – SMD version**

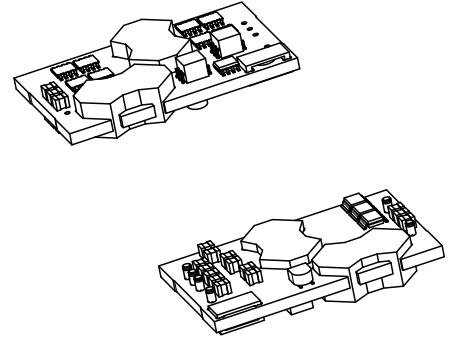
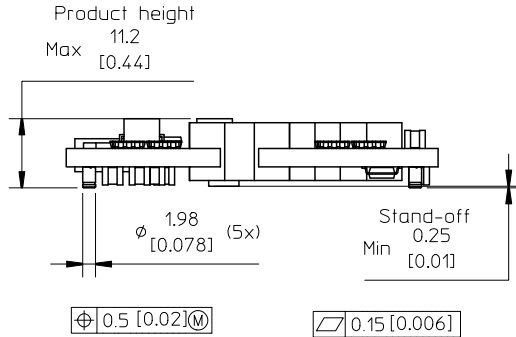

TOP VIEW

Pin positions according to recommended footprint

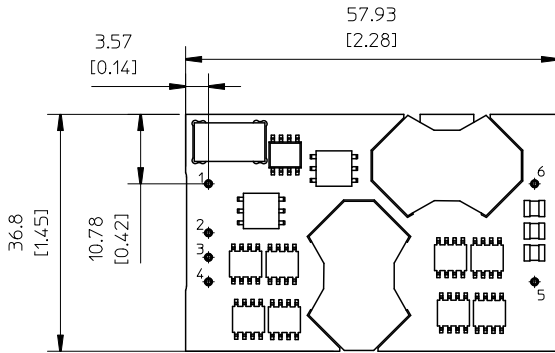

RECOMMENDED FOOTPRINT  
 TOP VIEW

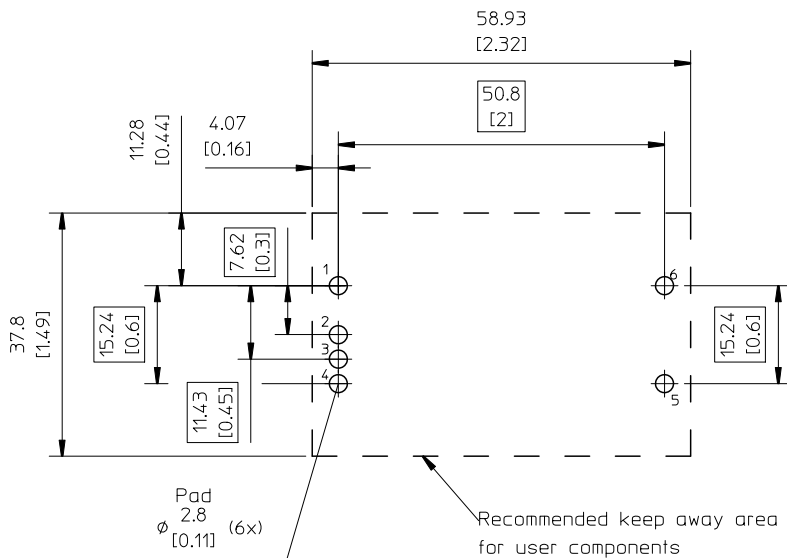

Pins:  
 Material: CuTe  
 Plating: 0.1 $\mu$ m Au over 2 $\mu$ m Ni

Weight: typical 45 g

All dimensions in mm [inch].  
 Tolerances unless specified:  
 x.x  $\pm$ 0.5 mm [0.02]  
 x.xx $\pm$ 0.25 mm [0.01]  
 (not applied on footprint or typical values)



**PKM4000B series Intermediate Bus Converters**  
Input 36-75 V, Output up to 33 A / 380 W

EN/LZT 146 305 R6B June 2010

© Ericsson AB

**Soldering Information – Surface Mounting**

The surface mount product is intended for forced convection or vapor phase reflow soldering in SnPb and Pb-free processes.

The reflow profile should be optimised to avoid excessive heating of the product. It is recommended to have a sufficiently extended preheat time to ensure an even temperature across the host PCB and it is also recommended to minimize the time in reflow.

A no-clean flux is recommended to avoid entrapment of cleaning fluids in cavities inside the product or between the product and the host board, since cleaning residues may affect long time reliability and isolation voltage.

**Minimum Pin Temperature Recommendations**

Pin number 5 is chosen as reference location for the minimum pin temperature recommendation since this will likely be the coolest solder joint during the reflow process.

**SnPb solder processes**

For SnPb solder processes, a pin temperature ( $T_{PIN}$ ) in excess of the solder melting temperature, ( $T_L$ , 183°C for Sn63Pb37) for more than 30 seconds and a peak temperature of 210°C is recommended to ensure a reliable solder joint.

For dry packed products only: depending on the type of solder paste and flux system used on the host board, up to a recommended maximum temperature of 245°C could be used, if the products are kept in a controlled environment (dry pack handling and storage) prior to assembly.

**Lead-free (Pb-free) solder processes**

For Pb-free solder processes, a pin temperature ( $T_{PIN}$ ) in excess of the solder melting temperature ( $T_L$ , 217 to 221°C for SnAgCu solder alloys) for more than 30 seconds and a peak temperature of 235°C on all solder joints is recommended to ensure a reliable solder joint.

**Maximum Product Temperature Requirements**

Top of the product PCB near pin 2 is chosen as reference location for the maximum (peak) allowed product temperature ( $T_{PRODUCT}$ ) since this will likely be the warmest part of the product during the reflow process.

**SnPb solder processes**

For SnPb solder processes, the product is qualified for MSL 1 according to IPC/JEDEC standard J-STD-020C.

During reflow  $T_{PRODUCT}$  must not exceed 225 °C at any time.

**Pb-free solder processes**

For Pb-free solder processes, the product is qualified for MSL 3 according to IPC/JEDEC standard J-STD-020C.

During reflow  $T_{PRODUCT}$  must not exceed 260 °C at any time.

**Dry Pack Information**

Products intended for Pb-free reflow soldering processes are delivered in standard moisture barrier bags according to IPC/JEDEC standard J-STD-033 (Handling, packing, shipping and use of moisture/reflow sensitivity surface mount devices).

Using products in high temperature Pb-free soldering processes requires dry pack storage and handling. In case the products have been stored in an uncontrolled environment and no longer can be considered dry, the modules must be baked according to J-STD-033.

General reflow process specifications	SnPb eutectic	Pb-free
Average ramp-up ( $T_{PRODUCT}$ )	3°C/s max	3°C/s max
Typical solder melting (liquidus) temperature	$T_L$ 183°C	221°C
Minimum reflow time above $T_L$	30 s	30 s
Minimum pin temperature	$T_{PIN}$ 210°C	235°C
Peak product temperature	$T_{PRODUCT}$ 225°C	260°C
Average ramp-down ( $T_{PRODUCT}$ )	6°C/s max	6°C/s max
Maximum time 25°C to peak	6 minutes	8 minutes

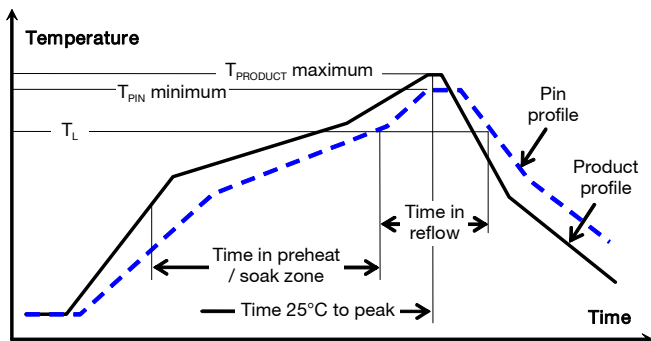

**Thermocoupler Attachment**

Pin 2 for measurement of maximum product temperature  $T_{PRODUCT}$

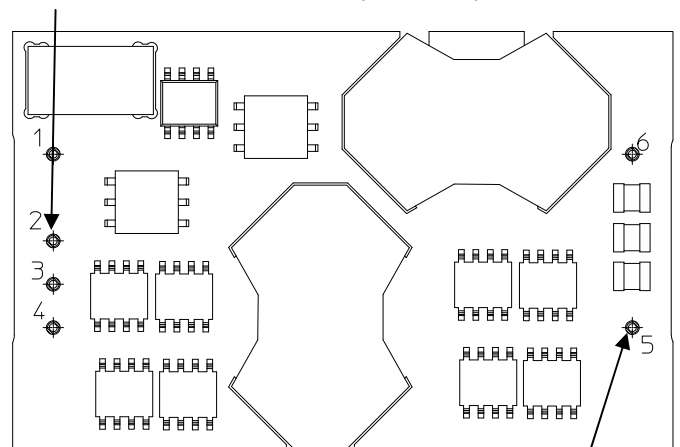

Pin 5 for measurement of minimum Pin (solder joint) temperature  $T_{PIN}$

**PKM4000B series Intermediate Bus Converters**  
 Input 36-75 V, Output up to 33 A / 380 W

EN/LZT 146 305 R6B June 2010

© Ericsson AB

**Delivery Package Information – Surface Mount Version**

The products are delivered in antistatic injection molded trays (Jedec design guide 4.10D standard).

Tray Specifications	
<b>Material</b>	Antistatic PPE
<b>Surface resistance</b>	$10^5 < \text{Ohm/square} < 10^{12}$
<b>Bakability</b>	The trays can be baked at maximum 125°C for 48 hours
<b>Tray thickness</b>	14.50 mm 0.571 [inch]
<b>Box capacity</b>	20 products (2 full trays/box)
<b>Tray weight</b>	125 g empty, 573 g full tray

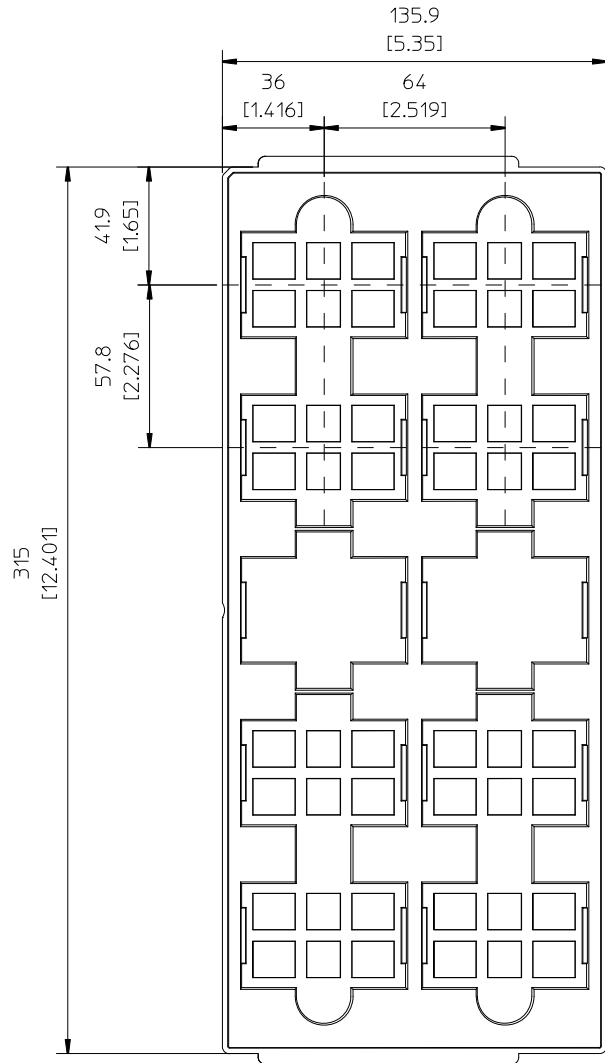

JEDEC standard tray for 2x5 = 10 products.  
 All dimensions in mm [inch]  
 Tolerances: X.x ±0.26 [0.01], X.xx ±0.13 [0.005]

Note: pick up positions refer to center of pocket.  
 See mechanical drawing for exact location on product.

**PKM4000B series Intermediate Bus Converters**  
 Input 36-75 V, Output up to 33 A / 380 W

EN/LZT 146 305 R6B June 2010

© Ericsson AB

**Soldering Information - Hole Mounting**

The hole mounted product is intended for plated through hole mounting by wave or manual soldering. The pin temperature is specified to maximum to 270°C for maximum 10 seconds.

A maximum preheat rate of 4°C/s and maximum preheat temperature of 150°C is suggested. When soldering by hand, care should be taken to avoid direct contact between the hot soldering iron tip and the pins for more than a few seconds in order to prevent overheating.

A no-clean flux is recommended to avoid entrapment of cleaning fluids in cavities inside the product or between the product and the host board. The cleaning residues may affect long time reliability and isolation voltage.

**Delivery Package Information – Hole Mount Version**

The products are delivered in antistatic trays.

Tray Specifications	
<b>Material</b>	PE Foam
<b>Surface resistance</b>	$10^5 < \text{Ohm/square} < 10^{12}$
<b>Bakability</b>	The trays are not bakeable
<b>Tray capacity</b>	20 converters/tray
<b>Box capacity</b>	20 products (2 full trays/box)
<b>Weight</b>	Product – Open frame 1100 g full tray, 140g empty tray Product – Base plate option 1480 g full tray, 140 g empty tray

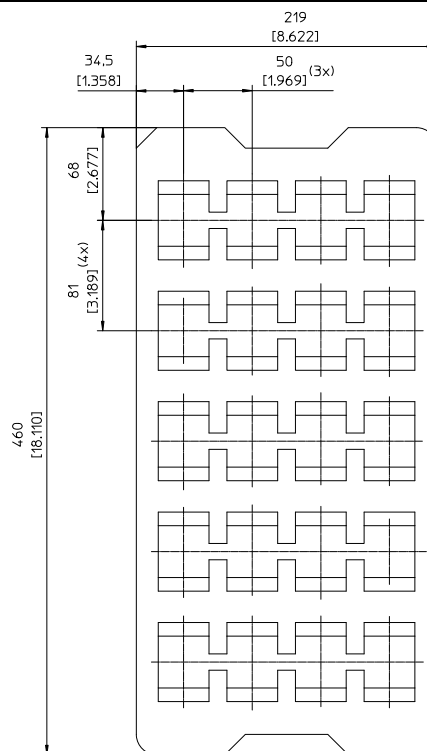

**PKM4000B series Intermediate Bus Converters**  
 Input 36-75 V, Output up to 33 A / 380 W

EN/LZT 146 305 R6B June 2010

© Ericsson AB

**Product Qualification Specification**

Characteristics			
External visual inspection	IPC-A-610		
Change of temperature (Temperature cycling)	IEC 60068-2-14 Na	Temperature range Number of cycles Dwell/transfer time	-40 to 100°C 1000 15 min/0-1 min
Cold (in operation)	IEC 60068-2-1 Ad	Temperature T <sub>A</sub> Duration	-45°C 72 h
Damp heat	IEC 60068-2-67 Cy	Temperature Humidity Duration	85°C 85 % RH 1000 hours
Dry heat	IEC 60068-2-2 Bd	Temperature Duration	125°C 1000 h
Electrostatic discharge susceptibility	IEC 61340-3-1, JESD 22-A114 IEC 61340-3-2, JESD 22-A115	Human body model (HBM) Machine Model (MM)	Class 2, 2000 V Class 3, 200 V
Immersion in cleaning solvents	IEC 60068-2-45 XA, method 2	Water Glycol ether Isopropyl alcohol	55°C 35°C 35°C
Mechanical shock	IEC 60068-2-27 Ea	Peak acceleration Duration	100 g 6 ms
Moisture reflow sensitivity <sup>1</sup>	J-STD-020C	Level 1 (SnPb-eutectic) Level 3 (Pb Free)	225°C 260°C
Operational life test	MIL-STD-202G, method 108A	Duration	1000 h
Resistance to soldering heat <sup>2</sup>	IEC 60068-2-20 Tb, method 1A	Solder temperature Duration	270°C 10-13 s
Robustness of terminations	IEC 60068-2-21 Test Ua1 IEC 60068-2-21 Test Ue1	Through hole mount products Surface mount products	All leads All leads
Solderability	IEC 60068-2-58 test Td <sup>1</sup>	Preconditioning Temperature, SnPb Eutectic Temperature, Pb-free	150°C dry bake 16 h 215°C 235°C
	IEC 60068-2-20 test Ta <sup>2</sup>	Preconditioning Temperature, SnPb Eutectic Temperature, Pb-free	Steam ageing 235°C 245°C
Vibration, broad band random	IEC 60068-2-64 Fh, method 1	Frequency Spectral density Duration	10 to 500 Hz 0.07 g <sup>2</sup> /Hz 10 min in each direction

**Notes**
<sup>1</sup> Only for products intended for reflow soldering (surface mount products)

<sup>2</sup> Only for products intended for wave soldering (plated through hole products)