

**KEY FEATURES**

- Switching Power Module for PCB Mountable
- High Efficiency up to 93% Typical
- Active PFC Function, >0.95 (230Vac), >0.99 (115Vac)
- Universal Input: 90-264 VAC
- Low Leakage Current, <250uA
- EN55022 Class B Meets
- Class I and Class II Construction
- Continuous Short Circuit Protection with Hiccup Mode and Auto Recover
- 3-Years Product Warranty

**ELECTRICAL SPECIFICATIONS**

Model No.	AQC100-12S	AQC100-15S	AQC100-24S	AQC100-48S
Max Output Wattage (W)	85 W	85W	100W	100W
Input	Voltage			
	90-264 VAC or 120-370 VDC			
	Frequency (Hz)			
	47-63 Hz			
	Current (Full load)			
	<2.0 A max. (115 VAC) / <1.0 A max. (230 VAC)			
Inrush Current (<2ms)				
< 30 A max. (115 VAC) / < 60 A max. (230 VAC)				
Leakage Current				
< 0.5 mA max.				
Power Factor				
PF>0.99 (115 VAC) / PF>0.95 (230 VAC) at Full Load				
Output	Voltage (V.DC.)			
	12V	15V	24V	48V
	Voltage Accuracy			
	±2%			
	Current (A) max			
	7.08	5.66	4.2	2.1
	Line Regulation			
	±1%			
	Load Regulation			
	±1%			
	Minimum Load			
0%				
Maximum Capacitive Load				
70,000µF	50,000µF	6,000µF	1,000µF	
Ripple & Noise max.				
120mV	150mV	200mV	240mV	
Efficiency (typ.)				
90%	90%	92%	93%	
Hold-up Time				
10 ms (110 VAC) min.				
Switching Frequency				
100 kHz				
Protection	Over Power Protection			
	Auto recovery, Hiccup mode			
	Over Voltage Protection			
Zener diode clamp				
Short Circuit Protection				
Auto recovery, Hiccup mode				
Isolation	Input-Output (V.AC)			
	3000V			
	Input-FG (V.AC)			
1500V				
Output-FG (V.AC)				
500V				
Environment	Operating Temperature			
	-25°C...+70°C (with derating)			
	Storage Temperature			
	-25°C...+85°C			
	Temperature Coefficient			
	±0.03%/°C ( 0~50°C )			
Humidity				
95% RH				
MTBF				
>250,000 h @ 25°C (MIL-HDBK-217F, Notice 1)				
Vibration				
10~500Hz, 2G 10min./1cycle, 60min. each along X, Y, Z axes.				
Physical	Dimension (L x W x H)			
	4.3 x 2.3 x 1.18 Inches ( 109.0 x 58.5 x 30.0 mm ) Tolerance ±0.1 mm			
	Weight			
310 g				
Cooling Method				
Free convection				
Safety	Agency Approvals			
CE, UL60950-1 (Pending)				
EMC	EMI (Conducted & Radiated Emission)			
	EN61000-6-3 · EN 55022 class B (Conductive plane to be connected to safety earth)			
EMS (Noise Immunity)				
EN 55024 · EN61000-4-2,3,4,5,6,8,11				

1.All specifications valid at nominal input voltage, full load and +25°C after warm-up time unless otherwise stated.

2.Ripple &amp; Noise are measured at 20MHz of bandwidth with 0.1UF &amp; 47UF parallel capacitor.

3.Hold-up Time measured at 90% Vout.

**MECHANICAL DIMENSION ( Top View )**

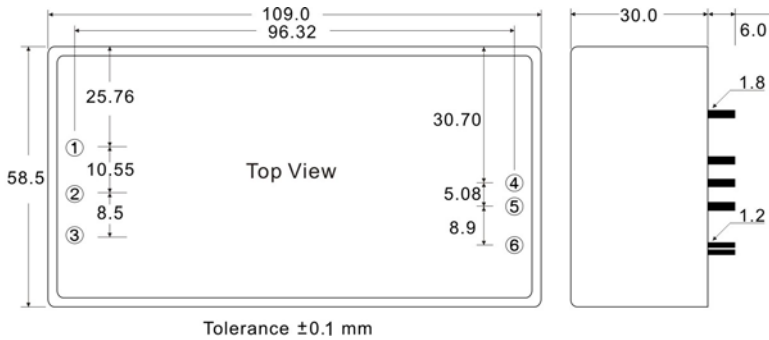

PIN#	SINGLE
1	AC IN (N)
2	AC IN (L)
3	FG
4	+DC OUT
5	-DC OUT
6	Trim

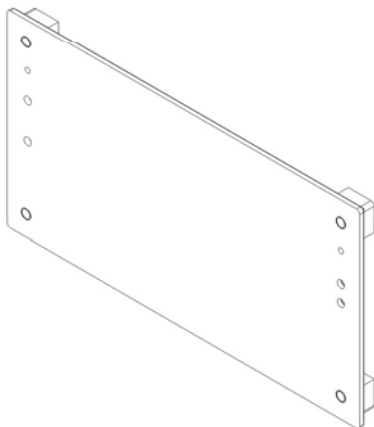
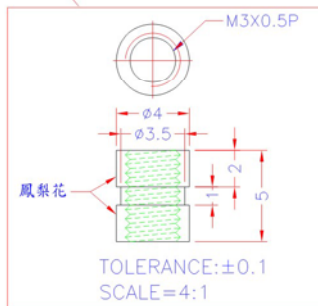
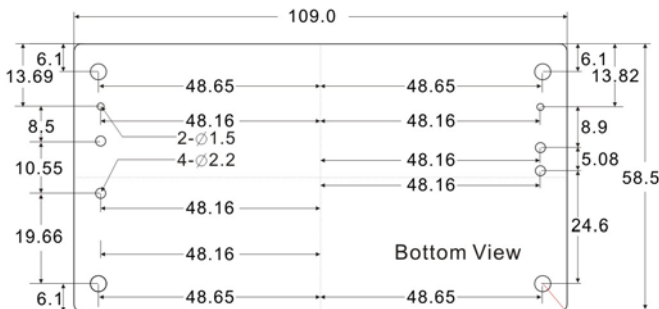

**DERATING**

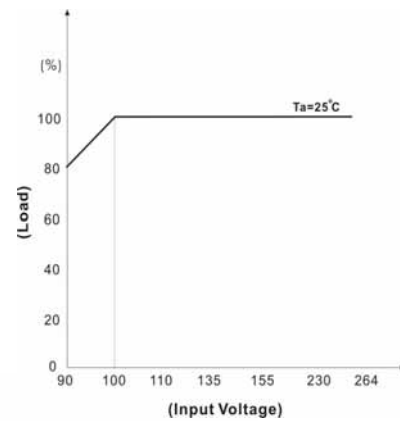
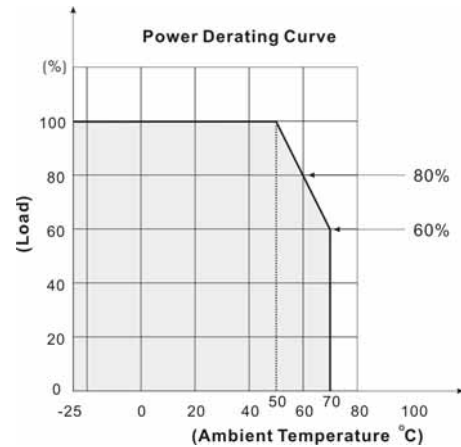

**BLOCK DIAGRAM**

Single Output

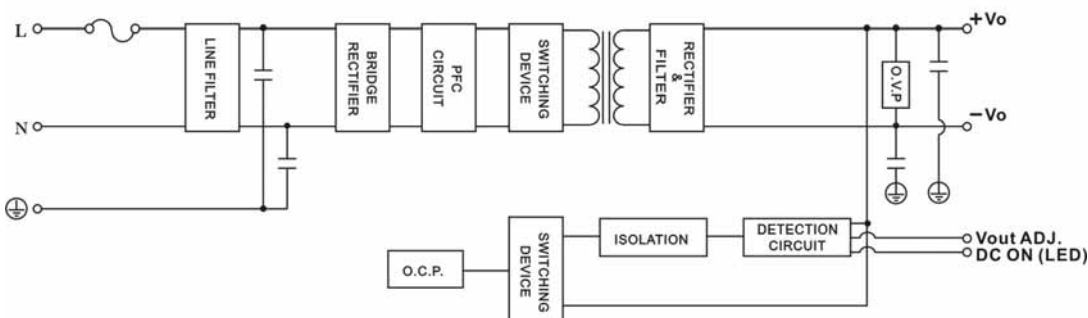

**EFFICIENCY VERSUS LOAD**

**AQC100-12S**

VIN VS Efficiency

Input Voltage (V)	90	115	180	230	264
Efficiency (%)	87.87	89.51	90.67	90.88	90.96

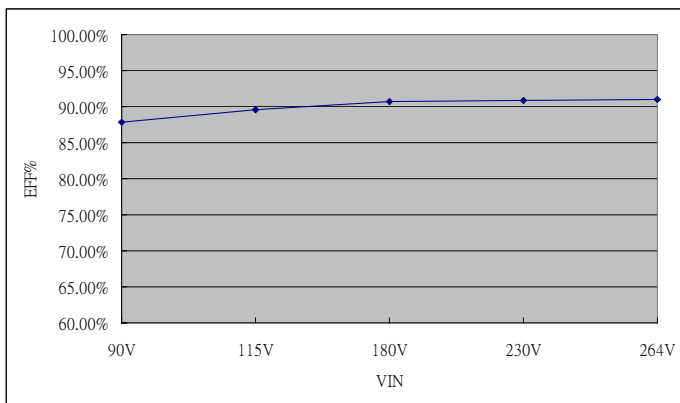

LOAD VS Efficiency

Load (%)	10	20	30	40	50
115V (%)	78.62	85.67	88.07	89.14	89.76
230V (%)	73.49	83.84	86.57	88.55	89.76
Load (%)	60	70	80	90	100
115V (%)	89.95	90.00	90.02	89.77	89.51
230V (%)	90.22	90.58	90.83	90.85	90.88

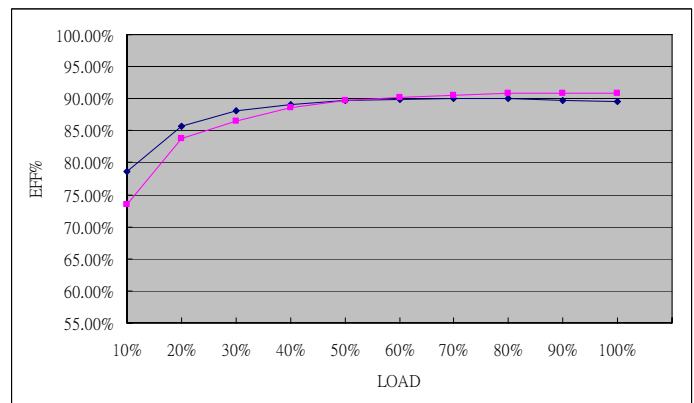

**AQC100-15S**

VIN VS Efficiency

Input Voltage (V)	90	115	180	230	264
Efficiency (%)	88.41	90.17	91.11	91.59	91.53

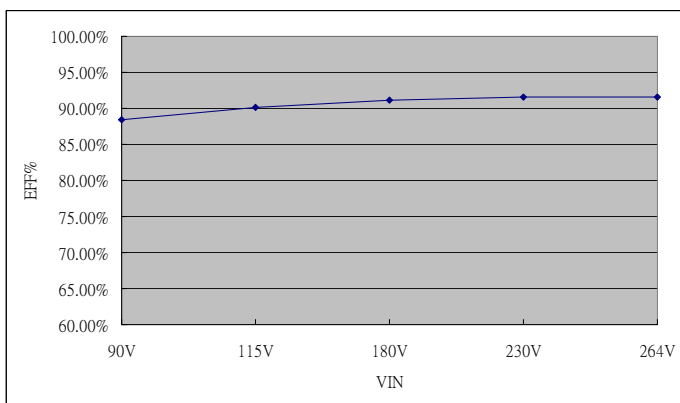

LOAD VS Efficiency

Load (%)	10	20	30	40	50
115V (%)	74.53	83.09	86.59	88.41	89.20
230V (%)	73.94	82.70	85.31	87.77	89.14
Load (%)	60	70	80	90	100
115V (%)	89.70	89.93	89.99	90.11	90.17
230V (%)	89.97	90.63	90.91	91.15	91.59

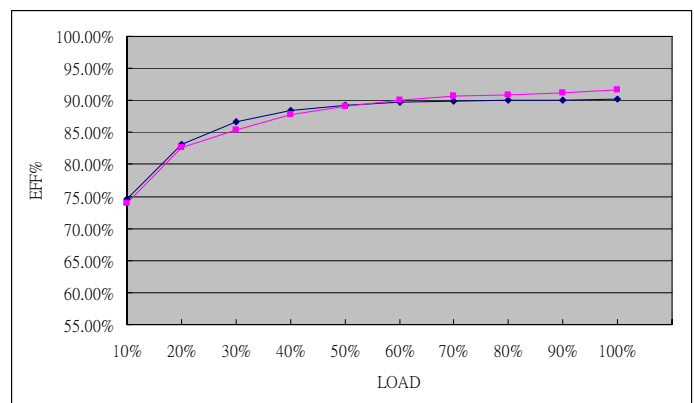

**EFFICIENCY VERSUS LOAD**

**AQC100-24S**

VIN VS Efficiency

Input Voltage (V)	90	115	180	230	264
Efficiency (%)	90.45	92.45	93.62	93.35	93.26

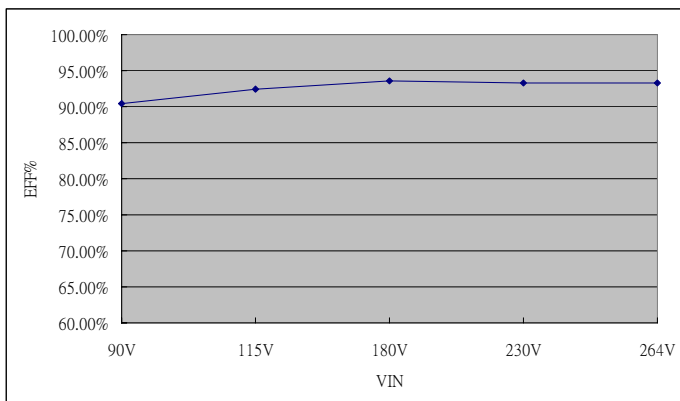

LOAD VS Efficiency

Load (%)	10	20	30	40	50
115V (%)	80.71	87.31	90.00	91.22	92.10
230V (%)	73.64	84.39	88.42	90.56	91.76
Load (%)	60	70	80	90	100
115V (%)	92.41	92.51	92.53	92.47	92.45
230V (%)	92.54	92.97	93.28	93.52	93.35

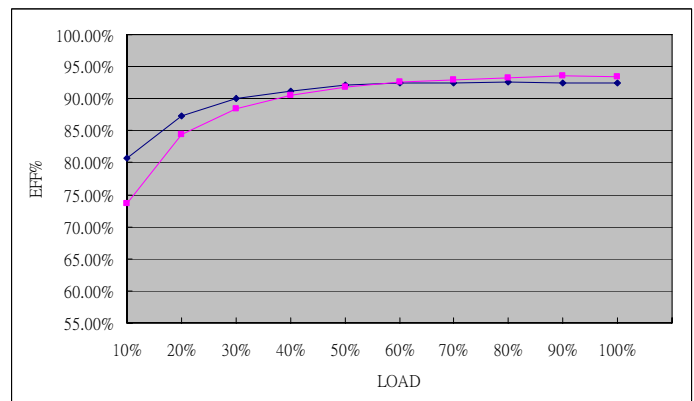

**AQC100-48S**

VIN VS Efficiency

Input Voltage (V)	90	115	180	230	264
Efficiency (%)	91.22	93.13	94.24	94.59	94.66

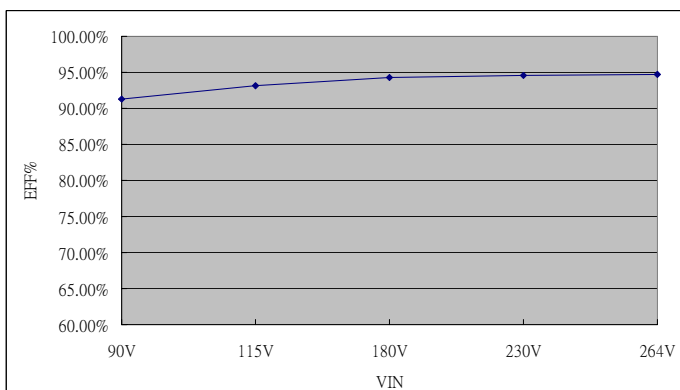

LOAD VS Efficiency

Load (%)	10	20	30	40	50
115V (%)	82.39	88.10	90.73	91.67	92.58
230V (%)	71.87	83.73	89.12	91.05	92.41
Load (%)	60	70	80	90	100
115V (%)	92.92	93.02	93.11	93.16%	93.13
230V (%)	93.18	93.63	93.95	94.32	94.59

